



DEPARTMENT OF REGULATORY AND ECONOMIC RESOURCES (RER)
BOARD AND CODE ADMINISTRATION DIVISION

NOTICE OF ACCEPTANCE (NOA)

MIAMI-DADE COUNTY
PRODUCT CONTROL SECTION
11805 SW 26 Street, Room 208
T (786) 315-2590 F (786) 315-2599
www.miamidade.gov/economy

PGT Industries
1070 Technology Drive
North Venice, FL 34275

SCOPE:

This NOA is being issued under the applicable rules and regulations governing the use of construction materials. The documentation submitted has been reviewed and accepted by Miami-Dade County RER - Product Control Section to be used in Miami Dade County and other areas where allowed by the Authority Having Jurisdiction (AHJ).

This NOA shall not be valid after the expiration date stated below. The Miami-Dade County Product Control Section (In Miami Dade County) and/or the AHJ (in areas other than Miami Dade County) reserve the right to have this product or material tested for quality assurance purposes. If this product or material fails to perform in the accepted manner, the manufacturer will incur the expense of such testing and the AHJ may immediately revoke, modify, or suspend the use of such product or material within their jurisdiction. RER reserves the right to revoke this acceptance, if it is determined by Miami-Dade County Product Control Section that this product or material fails to meet the requirements of the applicable building code.

This product is approved as described herein, and has been designed to comply with the Florida Building Code, including the High Velocity Hurricane Zone.

DESCRIPTION: Series "CA-640F Fixed Casement" Aluminum Fixed Window – N.I.

APPROVAL DOCUMENT: Drawing No. MD-CA640F-NI, titled "Fixed Casement Window Details – NI", sheets 1 through 10 of 10, dated 08/08/12, prepared by manufacturer, signed and sealed by Anthony Lynn Miller, P.E., bearing the Miami-Dade County Product Control Approval stamp with the Notice of Acceptance number and approval date by the Miami-Dade County Product Control Section.

MISSILE IMPACT RATING: None.

LABELING: Each unit shall bear a permanent label with the manufacturer's name or logo, city, state, model/series, and following statement: "Miami-Dade County Product Control Approved", unless otherwise noted herein.

RENEWAL of this NOA shall be considered after a renewal application has been filed and there has been no change in the applicable building code negatively affecting the performance of this product.

TERMINATION of this NOA will occur after the expiration date or if there has been a revision or change in the materials, use, and/or manufacture of the product or process. Misuse of this NOA as an endorsement of any product, for sales, advertising or any other purposes shall automatically terminate this NOA. Failure to comply with any section of this NOA shall be cause for termination and removal of NOA.

ADVERTISEMENT: The NOA number preceded by the words Miami-Dade County, Florida, and followed by the expiration date may be displayed in advertising literature. If any portion of the NOA is displayed, then it shall be done in its entirety.

INSPECTION: A copy of this entire NOA shall be provided to the user by the manufacturer or its distributors and shall be available for inspection at the job site at the request of the Building Official.

This NOA consists of this page 1 and evidence page E-1, as well as approval document mentioned above. The submitted documentation was reviewed by Manuel Perez, P.E.



MP
4/14/13

NOA No. 12-1218.12
Expiration Date: April 11, 2018
Approval Date: April 11, 2013
Page 1

PGT Industries

NOTICE OF ACCEPTANCE: EVIDENCE SUBMITTED

A. DRAWINGS

1. Manufacturer's die drawings and sections.
2. Drawing No. **MD-CA640F-NI**, titled "Fixed Casement Window Details – NI", sheets 1 through 10 of 10, dated 08/08/12, signed and sealed by Anthony Lynn Miller, P.E.

B. TESTS

1. Test reports on:
 - 1) Air Infiltration Test, per FBC, TAS 202-94
 - 2) Uniform Static Air Pressure Test, Loading per FBC TAS 202-94
 - 3) Water Resistance Test, per FBC, TAS 202-94along with marked-up drawings and installation diagram of a series CA640F aluminum fixed window, prepared by Fenestration Testing Laboratory, Inc. Test Report No. **FTL-7060**, dated 09/07/12, signed and sealed by Marlin D. Brinson, P.E.

C. CALCULATIONS

1. Anchor verification calculations and structural analysis, complying with FBC-2010, dated 12/07/12, prepared by manufacturer, signed and sealed by Anthony Lynn Miller, P.E.
2. Glazing complies with ASTM E1300-04

D. QUALITY ASSURANCE

1. Miami-Dade Department of Regulatory and Economic Resources (RER)

E. MATERIAL CERTIFICATIONS

1. None.

F. STATEMENTS

1. Statement letter of conformance, complying with **FBC-2010**, dated December 10, 2012, issued by manufacturer, signed and sealed by Anthony Lynn Miller, P.E.
2. Statement letter of no financial interest, dated December 10, 2012, issued by manufacturer, signed and sealed by Anthony Lynn Miller, P.E.
3. Proposal No. **12-1499** issued by Product Control, dated July 31, 2012, signed by Manuel Perez, P.E.

G. OTHER

1. None.

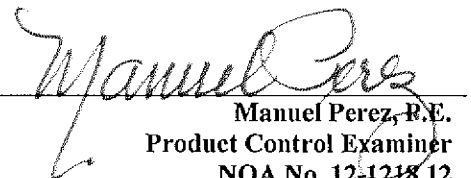
Manuel Perez, P.E.
Product Control Examiner
NOA No. 12-1218.12

Expiration Date: April 11, 2018

Approval Date: April 11, 2013

**GENERAL NOTES: SERIES 640
NON-IMPACT FIXED CASEMENT WINDOW**

DESIGN PRESSURE RATING	IMPACT RATING
VARIABLES, SEE SHEETS 6-9	NON-IMPACT RESISTANT

1) THIS PRODUCT HAS BEEN DESIGNED & TESTED TO COMPLY WITH THE REQUIREMENTS OF THE FLORIDA BUILDING CODE, INCLUDING THE HIGH VELOCITY HURRICANE ZONE (HVHZ).

2) SHUTTERS ARE REQUIRED WHEN USED IN WIND-BORNE DEBRIS REGIONS.

3) FOR MASONRY APPLICATIONS IN MIAMI-DADE COUNTY, USE ONLY MIAMI-DADE COUNTY APPROVED MASONRY ANCHORS. MATERIALS USED FOR ANCHOR EVALUATIONS WERE SOUTHERN PINE, ASTM C90 CONCRETE MASONRY UNITS AND CONCRETE WITH MIN. KSI PER ANCHOR TYPE, SEE TABLE 3, SHEET 4.

4) ALL WOOD BUCKS LESS THAN 1-1/2" THICK ARE TO BE CONSIDERED 1X INSTALLATIONS. 1X WOOD BUCKS ARE OPTIONAL IF UNIT IS INSTALLED DIRECTLY TO SUBSTRATE. WOOD BUCKS DEPICTED AS 2X ARE 1-1/2" THICK OR GREATER. 1X AND 2X BUCKS (WHEN USED) SHALL BE DESIGNED TO PROPERLY TRANSFER LOADS TO THE STRUCTURE. WOOD BUCK DESIGN AND INSTALLATION IS THE RESPONSIBILITY OF THE ENGINEER OR ARCHITECT OF RECORD.

5) ANCHOR EMBEDMENT TO BASE MATERIAL SHALL BE BEYOND WALL DRESSING OR STUCCO. USE ANCHORS OF SUFFICIENT EMBEDMENT AS SPECIFIED ON TABLE 3, SHEET 4. NARROW JOINT SEALANT IS USED ON ALL FOUR CORNERS OF THE FRAME. INSTALLATION ANCHORS SHOULD BE SEALED. OVERALL SEALING/FLASHING STRATEGY FOR WATER RESISTANCE OF INSTALLATION SHALL BE DONE BY OTHERS AND IS BEYOND THE SCOPE OF THESE INSTRUCTIONS.

6) SHIMS ARE REQUIRED AT EACH ANCHOR LOCATION WHERE THE PRODUCT IS NOT FLUSH TO THE SUBSTRATE. USE SHIMS CAPABLE OF TRANSFERRING APPLIED LOADS. WOOD BUCKS, BY OTHERS, MUST BE SUFFICIENTLY ANCHORED TO RESIST LOADS IMPOSED ON THEM BY THE WINDOW.

7) DESIGN PRESSURES:
A. NEGATIVE DESIGN LOADS BASED ON STRUCTURAL TEST PRESSURE, FRAME ANALYSIS AND GLASS PER ASTM E1300.
B. POSITIVE DESIGN LOADS BASED ON WATER TEST PRESSURE, STRUCTURAL TEST PRESSURE, FRAME ANALYSIS AND GLASS PER ASTM E1300.

8) THE ANCHORAGE METHODS SHOWN HAVE BEEN DESIGNED TO RESIST THE WINDLOADS CORRESPONDING TO THE REQUIRED DESIGN PRESSURE. THE 33-1/3% STRESS INCREASE HAS NOT BEEN USED IN THE DESIGN OF THIS PRODUCT. THE 1.6 LOAD DURATION FACTOR WAS USED FOR THE EVALUATION OF ANCHORS INTO WOOD. ANCHORS THAT COME INTO CONTACT WITH OTHER DISSIMILAR MATERIALS SHALL MEET THE REQUIREMENTS OF THE FLORIDA BUILDING CODE FOR CORROSION RESISTANCE.

9) REFERENCES: TEST REPORTS FTL-7060, 3579, 3580, 3724; ELCO ULTRACON NOA; ELCO CRETEFLEX NOA; ANSI/AF&PA NDS FOR WOOD CONSTRUCTION AND ADM ALUMINUM DESIGN MANUAL.

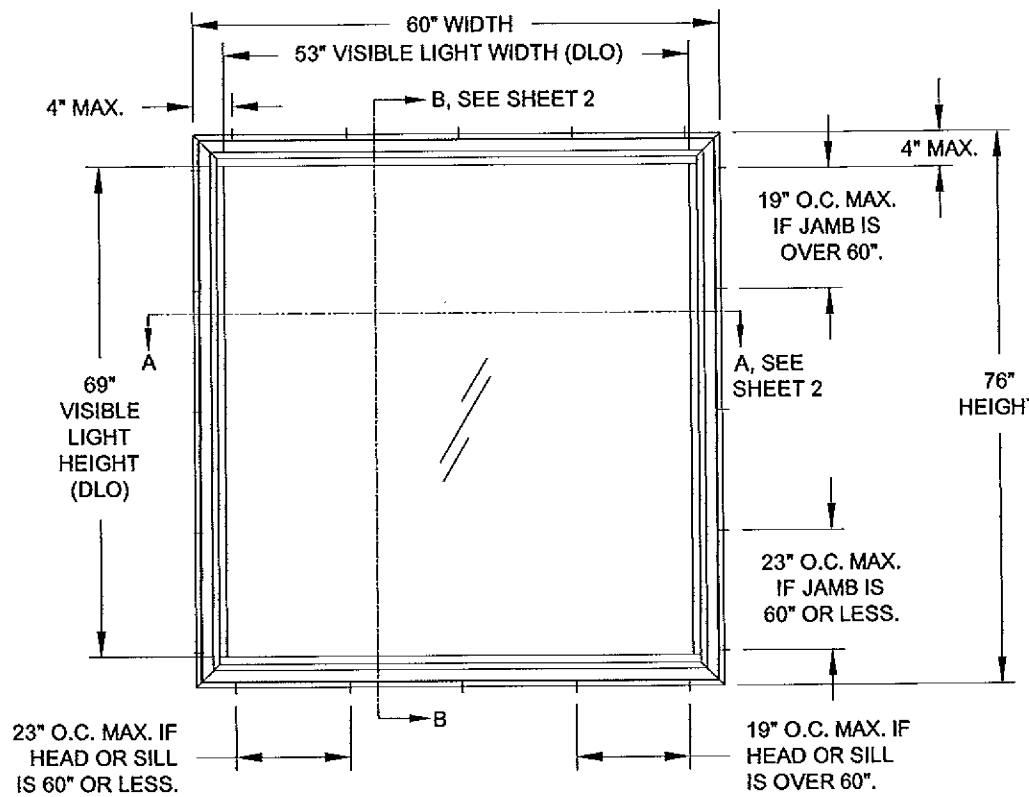

TYP. ELEVATION OF FIXED CASEMENT WINDOW

TABLE 1:

Glass Types	Sheet #
1 1/8" Annealed	6
2 1/8" Tempered	6
3 3/16" Annealed	7
4 3/16" Tempered	9
5 1/4" Annealed	7
6 1/4" Tempered	9
7 9/16" IG: (1/8" An - 5/16" Air - 1/8" An)	7
8 9/16" IG: (1/8" T - 5/16" Air - 1/8" T)	7
9 7/8" IG: (3/16" An - 1/2" Air - 3/16" An)	8
10 7/8" IG: (3/16" T - 1/2" Air - 3/16" T)	9

GENERAL NOTES.....	1
ELEVATION.....	1
GLAZING DETAILS.....	1
INSTALLATION.....	2
ASSEMBLY TUBE DETAILS.....	3
ANCHOR SPECIFICATIONS.....	4
ANCHOR QUANTITIES.....	4-5
DESIGN PRESSURES.....	6-9
ASSEMBLY DETAILS/BOM.....	10

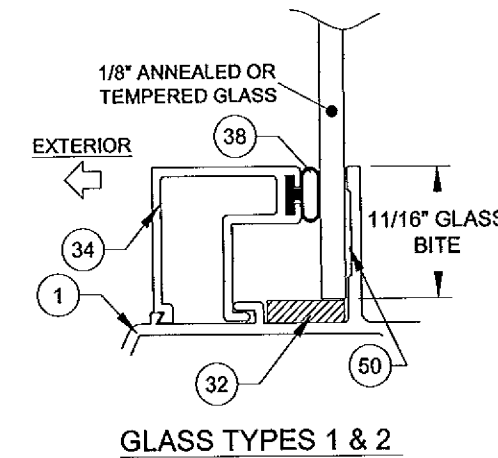

GLASS TYPES 1 & 2

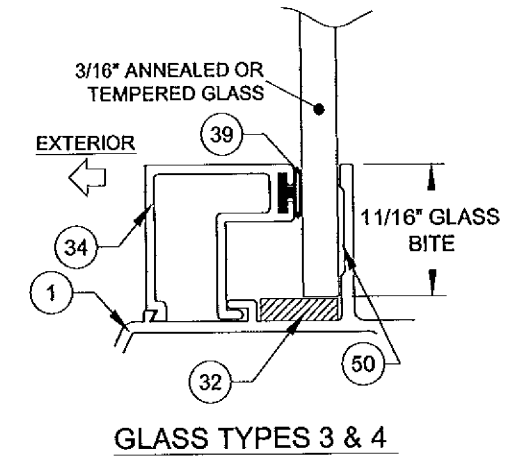

GLASS TYPES 3 & 4

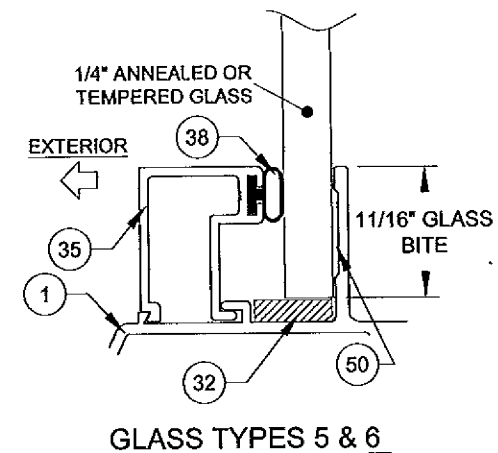

GLASS TYPES 5 & 6

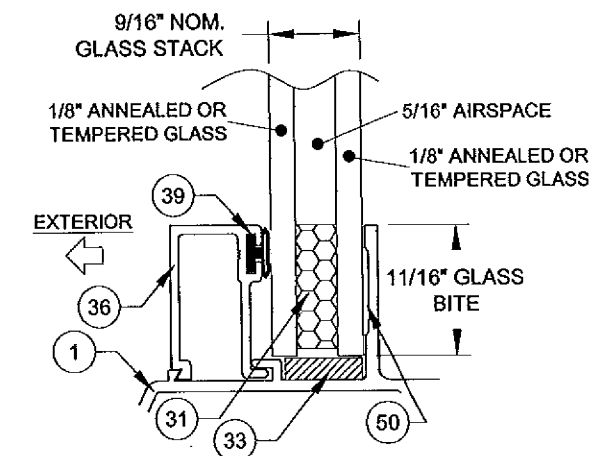

GLASS TYPES 7 & 8

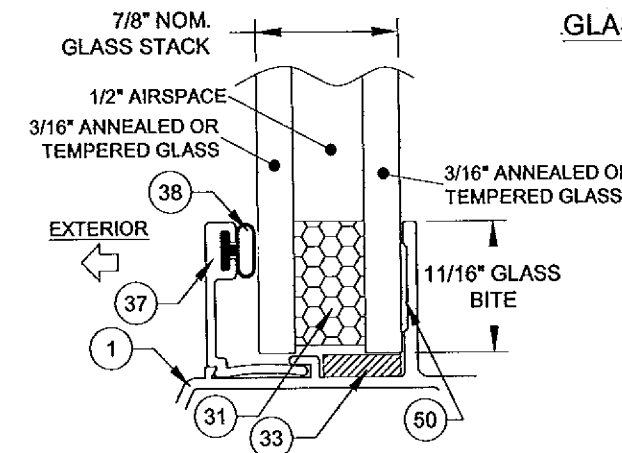

GLASS TYPES 9 & 10

Approved as complying with the Florida Building Code
Date: April 11, 2013
NOA# 12-1218-12
Miami Dade Product Control
By: *[Signature]*

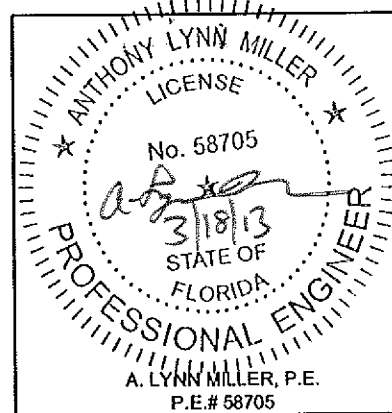

PGT
1070 TECHNOLOGY DRIVE
N. VENICE, FL 34275
P.O. BOX 1529
NOKOMIS, FL 34274
CERT. OF AUTH. #29296

Revised By:	Date:	Revision:
Revised By:	Date:	Revision:
Description: GENERAL NOTES & ELEVATION		Drawn By: J ROSOWSKI
Title: FIXED CASEMENT WINDOW DETAILS - NI		Date: 08/08/12
Series/Model: CA-640	Scale: NTS	Sheet: 1 OF 10
Drawing No. MD-CA640F-NI		Rev:

INSTALLATION OPTION 1
INSTALLATION ANCHORS INTO 2X WOOD.

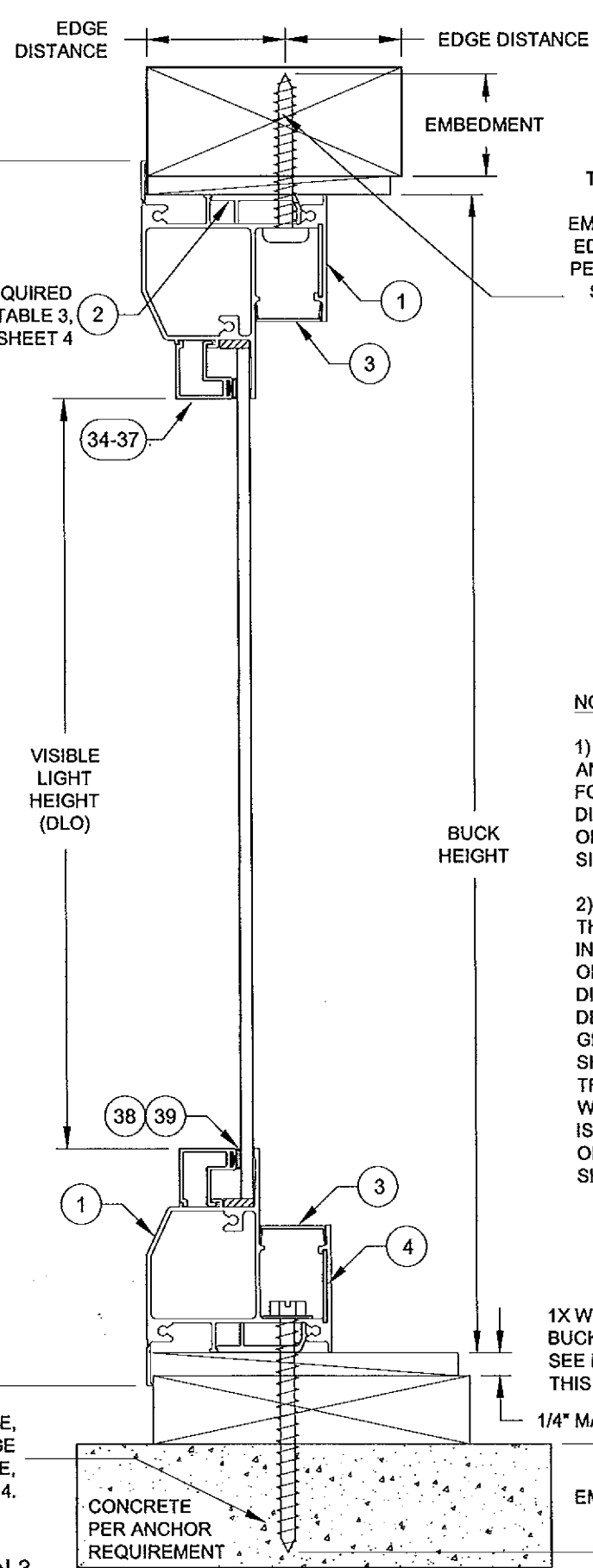

INSTALLATION OPTION 2
INSTALLATION ANCHORS DIRECTLY INTO MASONRY.

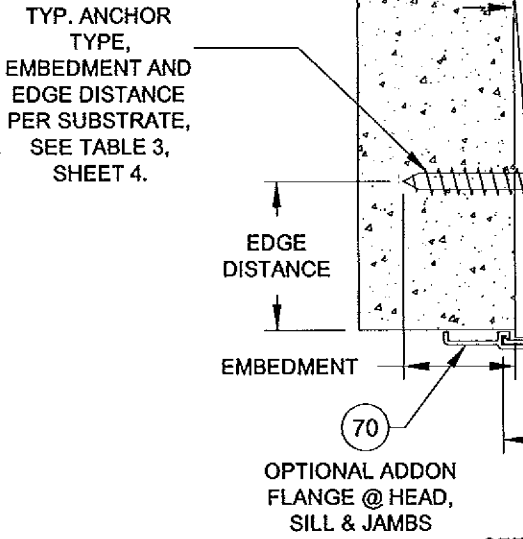

INSTALLATION OPTION 4
INSTALLATION ANCHORS DIRECTLY INTO METAL.

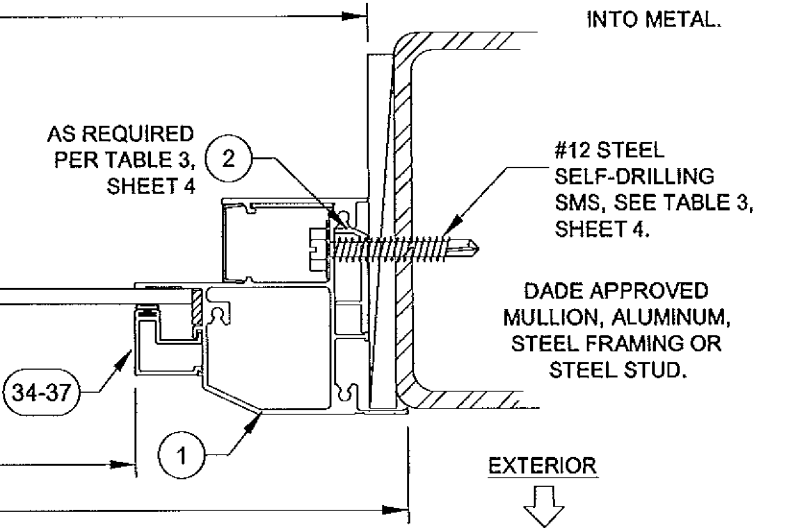

INSTALLATION OPTION 3
INSTALLATION ANCHORS THROUGH 1X BUCKSTRIP INTO MASONRY.

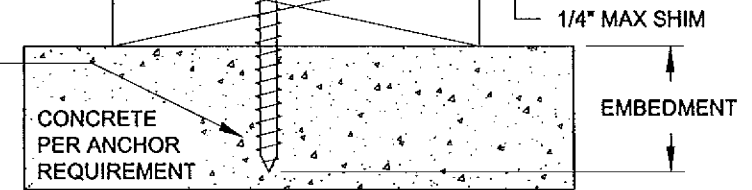

VERTICAL SECTION B-B

- NOTES:**
- 1) USE ONLY SUBSTRATE-APPROPRIATE ANCHORS LISTED ON TABLE 3, SHEET 4. FOLLOW EMBEDMENT AND EDGE DISTANCE LIMITS. ANY INSTALLATION OPTION SHOWN MAY BE USED ON ANY SIDE OF THE WINDOW.
 - 2) ALL WOOD BUCKS LESS THAN 1-1/2" THICK ARE TO BE CONSIDERED 1X INSTALLATIONS. 1X WOOD BUCKS ARE OPTIONAL. UNIT MAY BE INSTALLED DIRECTLY TO SUBSTRATE. WOOD BUCKS DEPICTED AS 2X ARE 1-1/2" THICK OR GREATER. 1X AND 2X BUCKS (WHEN USED) SHALL BE DESIGNED TO PROPERLY TRANSFER LOADS TO THE STRUCTURE. WOOD BUCK DESIGN AND INSTALLATION IS THE RESPONSIBILITY OF THE ENGINEER OR ARCHITECT OF RECORD. MAXIMUM SHIM THICKNESS TO BE 1/4".

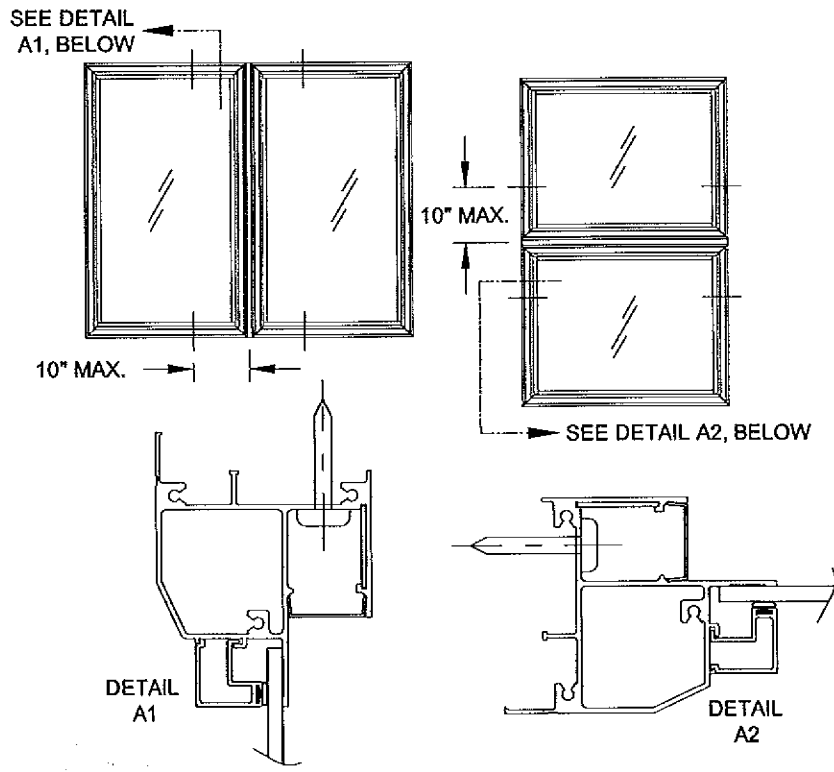

HORIZONTAL SECTION A-A

NOTES:

1) WHEN INSTALLING COMBINATION UNITS, ADDITIONAL INSTALLATION ANCHORS MAY NEED TO BE INSTALLED THROUGH THE WINDOW FRAMES AT 10" MAX. FROM EACH SIDE OF THE FRAME ASSEMBLY TUBE CENTERLINE. SEE TABLE BELOW:

Additional Anchors Required on each Side of the Frame Assembly Tube (FAT)			
Vertical FAT	Window Width	Anchor Type	
		A	B, C & D
Vertical FAT	17" - 22.9"	0	0
	23" - 25.9"	0	1
	26"+	1	1
Horizontal FAT	Window Height	Anchor Type	
		A	B, C & D
		17" - 22.9"	0
23" - 25.9"	0	1	
26"+	1	1	

VISIBLE LIGHT FORMULAS
WIDTH: WINDOW WIDTH - 7
HEIGHT: WINDOW HEIGHT - 7

Approved as complying with the Florida Building Code
Date: April 11, 2013
NOA# 12-1218-12
Miami Dade Product Control
By: Maureen [Signature]

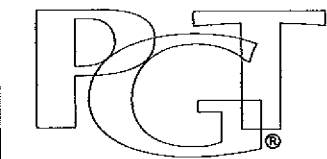
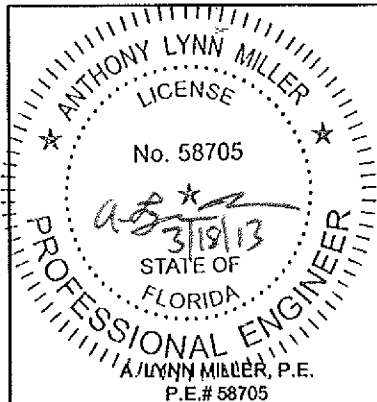

1070 TECHNOLOGY DRIVE
N. VENICE, FL 34275
P.O. BOX 1529
NOKOMIS, FL 34274

CERT. OF AUTH. #29296

Revised By:	Date:	Revision:
Revised By:	Date:	Revision:
Description: GENERAL NOTES & ELEVATION		Drawn By: J ROSOWSKI
Title: FIXED CASEMENT WINDOW DETAILS - NI		Date: 08/08/12
Series/Model: CA-640	Scale: NTS	Sheet: 2 OF 10
Drawing No. MD-CA640F-NI		Rev:

FIXED CASEMENT (O)

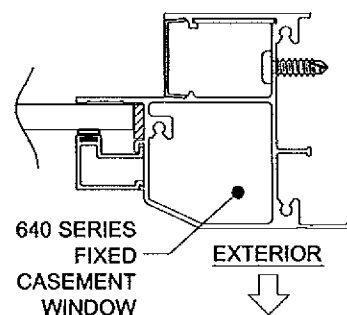
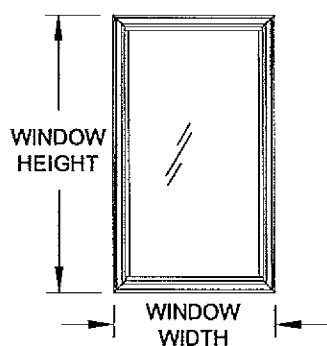

FOR SINGLE UNITS:

- 1) DETERMINE YOUR WINDOW SIZE AND GLASS.
- 2) KNOWING YOUR ANCHOR TYPE AND SUBSTRATE, DETERMINE YOUR ANCHOR GROUP FROM TABLE 3, SHEET 4.
- 3) FROM SHEETS 6-9, FIND THE SHEET FOR YOUR GLASS TYPE. FIND THE PRODUCT'S DESIGN PRESSURE FROM THE TABLE LABELED "DESIGN PRESSURE (PSF) FOR SINGLE WINDOWS, ALL ANCHOR GROUPS".
- 4) DIMENSIONS SHOWN ARE TIP-TO-TIP. FOR SIZES NOT SHOWN, ROUND UP TO THE NEXT AVAILABLE WIDTH OR HEIGHT DIMENSION SHOWN ON THE TABLES.
- 5) USING THE TABLES LABELED "WINDOW ANCHORS REQUIRED" (TABLES 2A & 2B, SHEETS 4 & 5), DETERMINE THE NUMBER OF ANCHORS NEEDED IN THE HEAD, SILL AND JAMBS OF YOUR WINDOW.
- 6) INSTALL AS PER THE INSTRUCTIONS ON SHEET 2.

FIXED CASEMENT / CASEMENT (OX)

FIGURE 1:

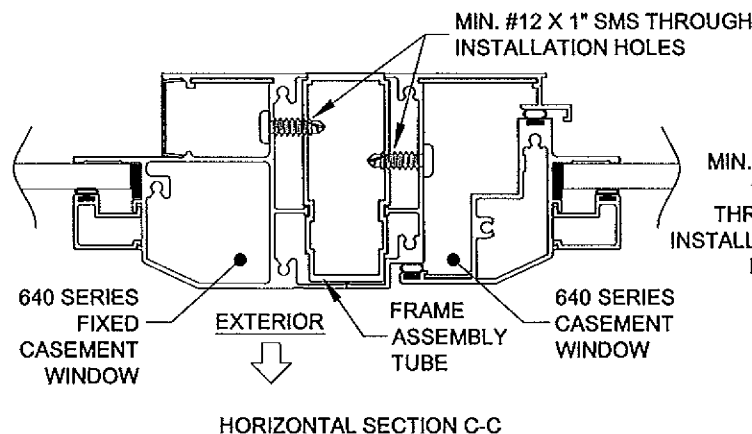
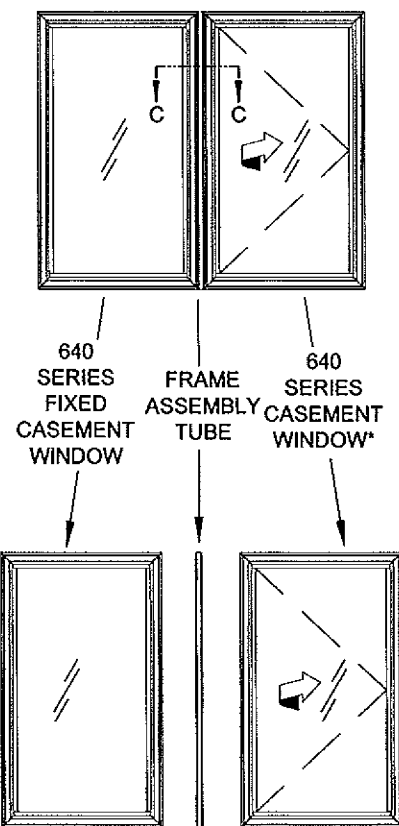

FOR EACH WINDOW IN A COMBINED ASSEMBLY:

- 1) DETERMINE EACH INDIVIDUAL WINDOW TYPE, SIZE AND GLASS MAKEUP, SEE FIGURES 1 & 2, THIS SHEET. DETERMINE YOUR ANCHOR GROUP FROM TABLE 3, SHEET 4.
- 2) FROM SHEETS 6-9, FIND THE SHEET FOR YOUR GLASS TYPE.
- 3) FIND THE DESIGN PRESSURE FROM THE TABLES LABELED "WINDOW ANCHORS REQUIRED" (TABLES 2A & 2B, SHEETS 4 & 5). THIS MUST BE DONE FOR EACH WINDOW IN THE ASSEMBLY, AND THE LOWEST DESIGN PRESSURE APPLIES TO THE ENTIRE ASSEMBLY. DIMENSIONS SHOWN ARE TIP-TO-TIP. FOR SIZES NOT SHOWN, ROUND UP TO THE NEXT AVAILABLE WIDTH OR HEIGHT DIMENSION SHOWN ON THE TABLES.
- 4) USING THE TABLE LABELED "WINDOW ANCHORS REQUIRED" (TABLES 2A & 2B, SHEETS 4 & 5), DETERMINE THE NUMBER OF ANCHORS NEEDED IN THE HEAD, SILL AND JAMBS OF YOUR WINDOW.
- 5) INSTALL AS PER THE INSTRUCTIONS ON SHEETS 2-3. NOTE THAT ADDITIONAL ANCHORS THROUGH THE WINDOW FRAME INTO THE SUBSTRATE MAY BE REQUIRED (SEE SHEET 2), AND THAT MIN. # 12 X 1" ANCHORS ARE TO BE USED THROUGH THE FRAME INTO THE FRAME ASSEMBLY TUBE (SEE DETAILS ON THIS SHEET).

AWNING / CASEMENT / FIXED CASEMENT (XXO)

FIGURE 2:

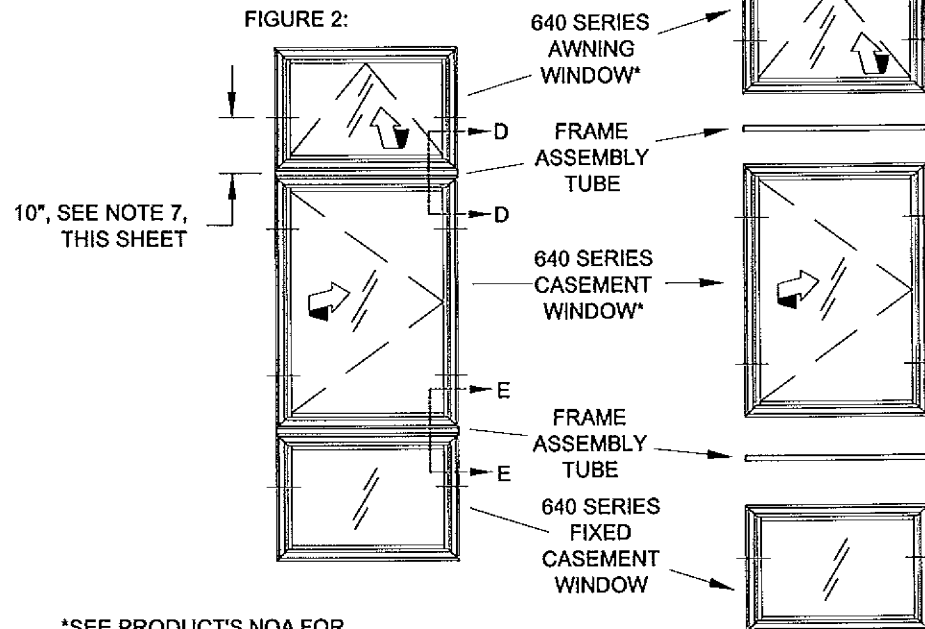

*SEE PRODUCT'S NOA FOR INSTALLATION SPECS

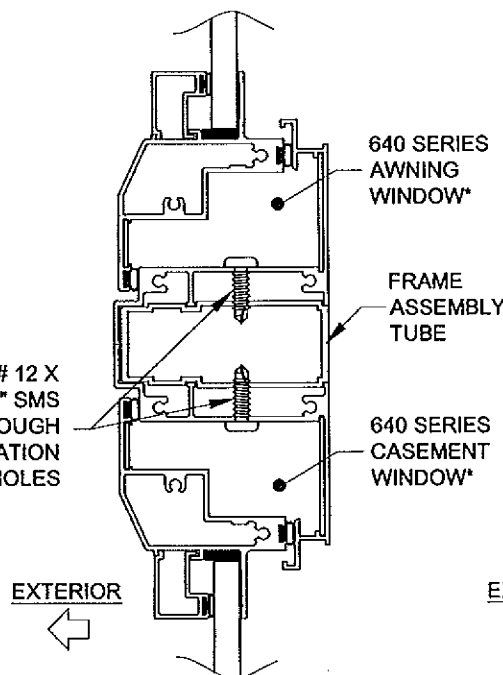

VERTICAL SECTION D-D

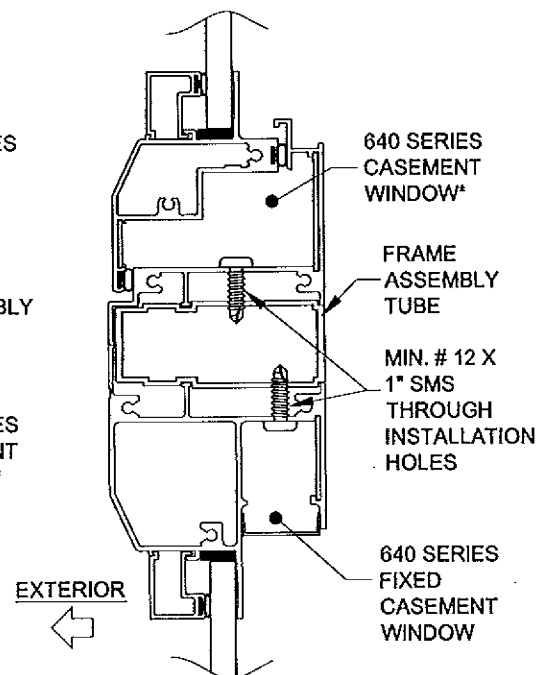

VERTICAL SECTION E-E

Approved as complying with the Florida Building Code
 Date: April 11, 2013
 NOA# 12-11218-17
 Miami Dade Product Control
 By: Manuel Lopez

FRAME ASSEMBLY TUBE NOTES:

- 1) DIMENSIONS SHOWN ARE TIP-TO-TIP DIMENSIONS FOR EACH INDIVIDUAL WINDOW. FOR SIZES NOT SHOWN, ROUND UP TO THE NEXT AVAILABLE WIDTH OR HEIGHT DIMENSION SHOWN ON THE TABLES.
- 2) ANY 640-SERIES PRODUCT (CASEMENT, AWNING OR FIXED CASEMENT) MAY BE ATTACHED TO THE FRAME ASSEMBLY TUBE. FOR ALL WINDOWS, USE THE WINDOW'S NOA FOR ANCHORAGE, SIZE AND DESIGN PRESSURE LIMITATIONS.
- 3) ALL WINDOWS IN THE COMBINATION UNIT MUST BE ABLE TO INDIVIDUALLY COMPLY WITH THE REQUIREMENTS OF THEIR RESPECTIVE NOA.
- 4) FRAME ASSEMBLY TUBE TO BE FASTENED TO WINDOW, AS SHOWN IN DETAILS, WITH MIN. #12 X 1" SHEET METAL SCREWS. USE THE SAME SPACING AND QUANTITY AS THE OPPOSITE FRAME MEMBER.
- 5) THE FRAME ASSEMBLY TUBE MAY NOT EXCEED 62" IN LENGTH (AS USED IN A 63" FLANGED WINDOW) OR BE USED IN TEE OR CROSS CONFIGURATIONS.
- 6) THE FRAME ASSEMBLY TUBE IS NOT REQUIRED TO BE CLIPPED TO THE SUBSTRATE. ALL EXTERIOR JOINTS TO BE SEALED BY INSTALLER.
- 7) FOR ALL COMBINATION UNITS, ADDITIONAL INSTALLATION ANCHORS MAY NEED TO BE INSTALLED THROUGH THE WINDOW FRAMES AT 10" MAX. FROM EACH SIDE OF THE FRAME ASSEMBLY TUBE CENTERLINE. SEE TABLE BELOW:

Additional Anchors Required on each Side of the Frame Assembly Tube (FAT)			
Vertical FAT	Window Width	Anchor Type	
		A	B, C & D
Vertical FAT	17" - 22.9"	0	0
	23" - 25.9"	0	1
	26"+	1	1
Horizontal FAT	Window Height	Anchor Type	
		A	B, C & D
Horizontal FAT	17" - 22.9"	0	0
	23" - 25.9"	0	1
	26"+	1	1

Revised:

Date:

Drawn By: **J ROSOWSKI**

Date: **08/08/12**

Description: **FRAME ASSEMBLY TUBE DETAILS**

Title: **FIXED CASEMENT WINDOW DETAILS - NI**

Series/Model: **CA-640**

Scale: **NTS**

Sheet: **3 OF 10**

Drawing No. **MD-CA640F-NI**

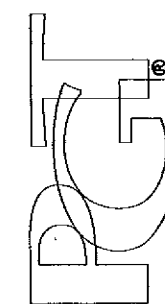

1070 TECHNOLOGY DRIVE
 N. VENICE, FL 34275
 P.O. BOX 1529
 NOKOMIS, FL 34274
 CERT. OF AUTH. #29296

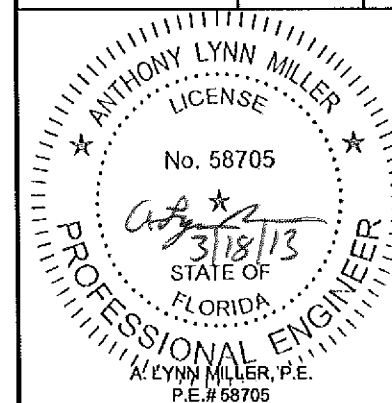

TABLE 2A:

Anchor Type		Window Width (in)																															
		under 23"				25-15/16"				27-3/4"				29"				31-1/2"				33-1/2"				34"				37"			
		A	B	C	D	A	B	C	D	A	B	C	D	A	B	C	D	A	B	C	D	A	B	C	D	A	B	C	D				
under 23"	Jamb	2	2	2	2	2	2	2	2	2	2	2	2	2	2	2	2	2	2	2	2	2	2	2	2	2	2	2	2	2	2	2	2
	Head/Sill	2	2	2	2	2	2	2	2	2	2	2	2	2	2	2	2	2	2	2	2	2	2	2	2	2	2	2	2	2	2	2	2
25-15/16"	Jamb	2	2	2	2	2	2	2	2	2	2	2	2	2	2	2	2	2	2	2	2	2	2	2	2	2	2	2	2	2	2	2	2
	Head/Sill	2	2	2	2	2	2	2	2	2	2	2	2	2	2	2	2	2	2	2	2	2	2	2	2	2	2	2	2	2	2	2	2
35"	Jamb	3	3	3	3	3	3	3	3	3	3	3	3	3	3	3	3	3	3	3	3	3	3	3	3	3	3	3	3	3	3	3	3
	Head/Sill	2	2	2	2	2	2	2	2	2	2	2	2	2	2	2	2	2	2	2	2	2	2	2	2	2	2	2	2	2	2	2	2
37"	Jamb	3	3	3	3	3	3	3	3	3	3	3	3	3	3	3	3	3	3	3	3	3	3	3	3	3	3	3	3	3	3	3	3
	Head/Sill	2	2	2	2	2	2	2	2	2	2	2	2	2	2	2	2	2	2	2	2	2	2	2	2	2	2	2	2	2	2	2	2
44"	Jamb	3	4	3	3	3	4	3	3	4	4	3	3	4	5	3	3	4	5	3	3	4	5	3	3	4	5	3	3	4	5	3	3
	Head/Sill	2	2	2	2	2	2	2	2	2	2	2	2	2	2	2	2	2	2	2	2	2	2	2	2	2	2	2	2	2	2	2	2
44-1/4"	Jamb	4	5	3	3	4	5	3	3	4	5	3	3	4	5	3	3	4	6	3	3	4	6	3	3	4	6	3	3	5	6	3	3
	Head/Sill	2	2	2	2	2	2	2	2	2	2	2	2	2	2	2	2	2	2	2	2	2	2	2	2	2	2	2	2	2	2	2	2
53-1/8"	Jamb	4	5	3	3	4	5	3	3	5	6	3	3	5	6	3	3	5	6	4	3	5	6	4	3	5	6	4	3	5	6	4	3
	Head/Sill	2	2	2	2	2	2	2	2	2	2	2	2	2	2	2	2	2	2	2	2	2	2	2	2	2	2	2	2	2	2	2	2
58"	Jamb	4	6	3	3	5	6	3	3	5	6	4	3	5	6	4	3	5	7	4	4	6	7	4	4	6	7	4	4	6	7	4	4
	Head/Sill	2	2	2	2	2	2	2	2	2	2	2	2	2	2	2	2	2	2	2	2	2	2	2	2	2	2	2	2	2	2	2	2
63"	Jamb	5	6	4	4	5	7	4	4	6	7	4	4	6	7	4	4	6	8	4	4	6	8	4	4	6	8	5	4	7	8	5	4
	Head/Sill	2	2	2	2	2	2	2	2	2	2	2	2	2	2	2	2	2	2	2	2	2	2	2	2	2	2	2	2	2	2	2	2
66-13/16"	Jamb	5	7	5	5	6	7	5	5	6	7	5	5	6	8	5	5	6	8	5	5	6	8	5	5	6	8	5	5	6	8	5	5
	Head/Sill	2	2	2	2	2	2	2	2	2	2	2	2	2	2	2	2	2	2	2	2	2	2	2	2	2	2	2	2	2	2	2	2
67-1/2"	Jamb	5	7	5	5	6	7	5	5	6	8	5	5	6	8	5	5	6	8	5	5	6	8	5	5	6	8	5	5	6	8	5	5
	Head/Sill	2	2	2	2	2	2	2	2	2	2	2	2	2	2	2	2	2	2	2	2	2	2	2	2	2	2	2	2	2	2	2	2
68"	Jamb	5	7	5	5	6	7	5	5	6	8	5	5	6	8	5	5	6	8	5	5	6	8	5	5	6	8	5	5	6	8	5	5
	Head/Sill	2	2	2	2	2	2	2	2	2	2	2	2	2	2	2	2	2	2	2	2	2	2	2	2	2	2	2	2	2	2	2	2
70"	Jamb	6	7	5	5	6	8	5	5	6	8	5	5	6	8	5	5	6	8	5	5	6	8	5	5	6	8	5	5	6	8	5	5
	Head/Sill	2	2	2	2	2	2	2	2	2	2	2	2	2	2	2	2	2	2	2	2	2	2	2	2	2	2	2	2	2	2	2	2
72"	Jamb	6	7	5	5	6	8	5	5	6	8	5	5	6	8	5	5	6	8	5	5	6	8	5	5	6	8	5	5	6	8	5	5
	Head/Sill	2	2	2	2	2	2	2	2	2	2	2	2	2	2	2	2	2	2	2	2	2	2	2	2	2	2	2	2	2	2	2	2
74"	Jamb	6	7	5	5	6	8	5	5	6	8	5	5	6	8	5	5	6	8	5	5	6	8	5	5	6	8	5	5	6	8	5	5
	Head/Sill	2	2	2	2	2	2	2	2	2	2	2	2	2	2	2	2	2	2	2	2	2	2	2	2	2	2	2	2	2	2	2	2
76"	Jamb	6	8	5	5	7	8	5	5	7	9	5	5	7	9	5	5	7	9	5	5	7	9	5	5	7	9	5	5	7	9	5	5
	Head/Sill	2	2	2	2	2	2	2	2	2	2	2	2	2	2	2	2	2	2	2	2	2	2	2	2	2	2	2	2	2	2	2	2
84"	Jamb	7	8	5	5	7	9	5	5	8	10	5	5	8	10	5	5	8	10	5	5	8	10	5	5	8	10	5	5	8	10	5	5
	Head/Sill	2	2	2	2	2	2	2	2	2	2	2	2	2	2	2	2	2	2	2	2	2	2	2	2	2	2	2	2	2	2	2	2
114"	Jamb	9	12	7	7	10	13	7	7	11	14	8	7	11	14	8	7	12	15	8	8	13	16	9	8	13	16	9	8	14	17	10	9
	Head/Sill	2	2	2	2	2	2	2	2	2	2	2	2	2	2	2	2	2	2	2	2	2	2	2	2	2	2	2	2	2	2	2	2
134"	Jamb	11	14	8	8	12	15	9	8	13	16	9	8	13	17	9	9	14	18	10	9	15	19	11	10	15	19	11	10				
	Head/Sill	2	2	2	2	2	2	2	2	2	2	2	2	2	2	2	2	2	2	2	2	2	2	2	2	2	2	2	2				
145"	Jamb	12	15	9	9	13	17	9	9	14	18	10	9	15	18	10	9	16	20	11	10												
	Head/Sill	2	2	2	2	2	2	2	2	2	2	2	2	2	2	2	2	2	2	2	2												

1) USE THIS TABLE FOR ALL WINDOWS PER THE ELEVATIONS ON SHEET 1. DIMENSIONS SHOWN ARE TIP-TO-TIP.

2) FOR SIZES NOT SHOWN, ROUND UP TO THE NEXT AVAILABLE WIDTH OR HEIGHT DIMENSION SHOWN ON THE TABLE.

TABLE 3:

Group	Anchor	Substrate	Min. Edge Distance	Min. O.C. Distance	Min. Embedment	Anchor Plate Required?
A	1/4" steel Ultracon	Hollow Block	1"	6"	1-1/4"	No
	#14, steel SMS (G5) or #14, 410 SS SMS	S. Pine	5/8"	1"	1-3/8"	No
		6063-T5 Alum.	3/8"	5/8"	0.050	No
		A36 Steel	3/8"	5/8"	0.050	No
		A653 Stud, Gr. 33	3/8"	5/8"	.035", 20 Ga.	No
B	#12, steel SMS (G5) or #12, 410 SS SMS	S. Pine	5/8"	1"	1-3/8"	No
		6063-T5 Alum.	3/8"	5/8"	.050"	No
		A36 Steel	3/8"	5/8"	.050"	No
		A653 Stud, Gr. 33	3/8"	5/8"	.035", 20 Ga.	No
C	1/4" steel Ultracon	2.85k Concrete	2-1/2"	4"	1-3/8"	No
		2.85k Concrete	1"	4"	1-3/4"	No
		Hollow Block	2-1/2"	5"	1-1/4"	No
	#12, steel SMS (G5) or #12, 410 SS SMS	S. Pine	5/8"	1"	1-3/8"	Yes
		6063-T5 Alum.	3/8"	5/8"	1/16"	Yes
A36 Steel		3/8"	5/8"	.050"	Yes	
A653 Stud, Gr. 33	3/8"	5/8"	.045", 18 Ga.	Yes		

TABLE 3: (cont.)

Group	Anchor	Substrate	Min. Edge Distance	Min. O.C. Distance	Min. Embedment	Anchor Plate Required?
D	#14, steel SMS (G5) or #14, 410 SS SMS	S. Pine	5/8"	1"	1-3/8"	Yes
		6063-T5 Alum.	3/8"	5/8"	1/16"	Yes
		A36 Steel	3/8"	5/8"	.050"	Yes
		A653 Stud, Gr. 33	3/8"	5/8"	.045", 18 Ga.	Yes
	1/4" steel Ultracon	2.85k Concrete	1"	4"	1-3/4"	Yes
		2.85k Concrete	2-1/2"	4"	1-3/8"	Yes
		Hollow Block	2-1/2"	5"	1-1/4"	Yes
		Filled Block	2-1/2"	4"	1-3/4"	Yes
	1/4" 410 SS CreteFlex	3.35k Concrete	1"	5"	1-3/4"	No
		Hollow Block	2-1/2"	5"	1-1/4"	No
5/16" steel Ultracon	3.5k Concrete	1-1/4"	5"	1-3/4"	No	
	Hollow Block	3-1/8"	5"	1-1/4"	No	
Filled Block	2-1/2"	5"	1-3/4"	No		

1) ANCHOR MUST EXTEND A MINIMUM OF 3 THREADS BEYOND ANY METAL SUBSTRATE.
2) ANCHORS MAY BE HEXHEAD, PANHEAD OR FLATHEAD.

Approved as complying with the Florida Building Code
Date: APR 11 2013
NOA# 12-1218-12
Miami Dade Product Control
By: Mauro Lopez

Revised By: J ROSOWSKI
Date: 08/08/12
Title: ANCHOR TYPE AND QUANTITY
Description: FIXED CASEMENT WINDOW DETAILS - NI
Series/Model: CA-640
Scale: NTS
Sheet: 4 OF 10
Drawing No.: MD-CA640F-NI

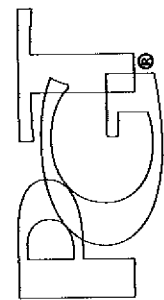

1070 TECHNOLOGY DRIVE
N. VENICE, FL 334275
P.O. BOX 1529
NOKOMIS, FL 34274
CERT. OF AUTH. #28296
ANTHONY LYNN MILLER
LICENSE
No. 58705
3/18/13
STATE OF FLORIDA
PROFESSIONAL ENGINEER
A. LYNN MILLER, P.E.
P.E.# 58705

