

PW3020 SILL

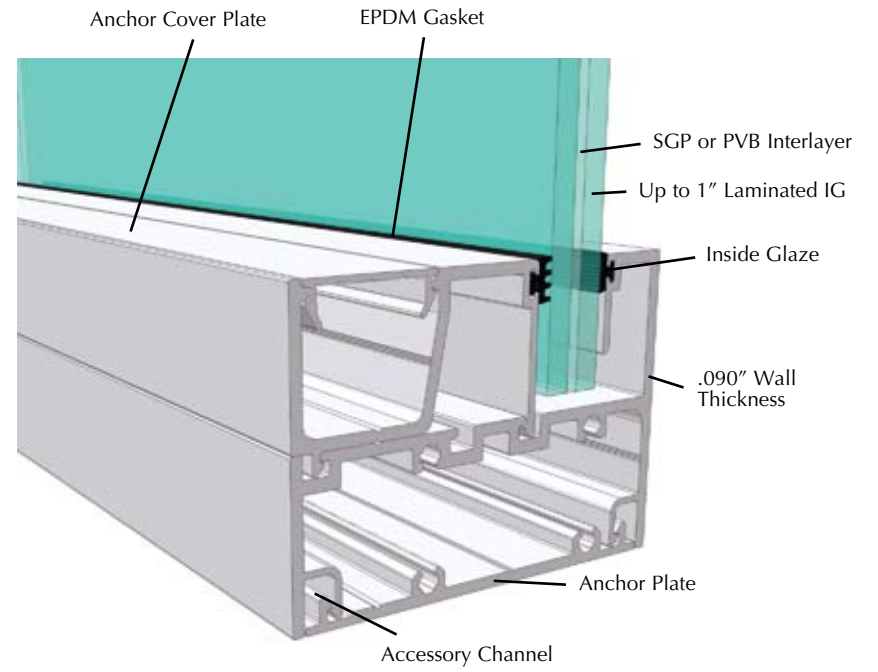

PICTURE WINDOWS

FEATURES & BENEFITS

INSIDE GLAZED

Simplified serviceability. Glass and bead can be replaced from inside the building.

MALE & FEMALE FRAME OPTION

Eliminates the need for mulls and clips. Vertical and horizontal preparation allows you to stack units next to each other, reducing installation costs because there are fewer components.

UP TO 1" LAMINATED INSULATING GLASS

Expands design and energy options.

DOUBLE APPLIED MUNTINS

Aesthetic option. Customize product to meet historical or building requirements. Available with grids between glass on insulated units.

MARINE GLAZING BEAD AESTHETICS

Resist fading or shrinking. High quality EPDM glazing gasket.

ACCESSORY CHANNEL

Extruded aluminum groove receives anchor plate or accessory options to ensure snug installation.

3000 SERIES

PRODUCT SPECIFICATIONS - PW3020

TEST TYPE	FRAME TYPE & MAXIMUM SIZE	FRAME DEPTH	POSITIVE DESIGN PRESSURE	NEGATIVE DESIGN PRESSURE	WATER RESISTANCE	AIR INFILTRATION	GLAZING	TESTS COMPLETED
LARGE MISSILE	FLANGE: 49½" x 121½" or 75½" x 79½" EQUAL LEG: 48" x 120" or 74" x 78"	3¼"	+130	-130	19.5 psf	<0.01 @ 1.57 <0.01 @ 6.24	<ul style="list-style-type: none"> • ⅜" SGP Laminated (Heat Strengthened/Heat Strengthened) • Up to 1" Laminated Insulating Glass 	<ul style="list-style-type: none"> • Miami-Dade NOA: 07-0613.02 • Forced Entry Resistance: ASTM F 842-97 • Florida Product Approval: FL-243
SMALL MISSILE	FLANGE: 49½" x 121½" or 75½" x 79½" EQUAL LEG: 48" x 120" or 74" x 78"	3¼"	+165	-165	24.75 psf	<0.01 @ 1.57 <0.01 @ 6.24	<ul style="list-style-type: none"> • ⅜" PVB Laminated (Tempered/Tempered) • Up to 1" Laminated Insulating Glass 	<ul style="list-style-type: none"> • Miami-Dade NOA: Pending • Forced Entry Resistance: ASTM F 842-97 • Florida Product Approval: FL-243