

GENERAL NOTES :

IMPACT-RESISTANT

1) THE ANCHORAGE METHODS SHOWN HAVE BEEN DESIGNED TO COMPLY WITH THE FLORIDA BUILDING CODE FOR THE DESIGN PRESSURES LISTED.

2) WOOD BUCKS DEPICTED AS 1X ARE LESS THAN 1-1/2" THICK. 1X WOOD BUCKS ARE OPTIONAL IF UNIT IS INSTALLED DIRECTLY TO SOLID CONCRETE. WOOD BUCKS DEPICTED AS 2X ARE 1-1/2" THICK OR GREATER. ATTACHMENT METHOD OF WOOD BUCKS SHALL BE DONE BY OTHERS.

3) SEE TABLES FOR MINIMUM EDGE DISTANCE FROM CENTER OF ANCHOR TO SUBSTRATE EDGE (EXCLUDING FINISH OR STUCCO).

4) SHIM EACH ANCHOR LOCATION WHERE THE PRODUCT IS NOT FLUSH TO THE SUBSTRATE, USING SHIMS CAPABLE OF TRANSFERRING APPLIED LOADS.

5) ANCHORS SHALL BE COATED OR CORROSION RESISTANT AS APPROPRIATE FOR SUBSTRATE MATERIAL. DISSIMILAR MATERIALS SHALL BE PROTECTED AS REQUIRED TO PREVENT REACTIONS. ALUMINUM SHALL BE PROTECTED FROM DISSIMILAR MATERIALS AS SPECIFIED IN FLORIDA BUILDING CODE CHAPTER 20.

6) ADHESIVE SEALANT SHALL BE USED BETWEEN SUBSTRATE AND FLANGE OR FIN. OVERALL SEALING/FLASHING STRATEGY FOR WATER RESISTANCE OF INSTALLATION SHALL BE DONE BY OTHERS.

7) MATERIALS USED FOR ANCHOR EVALUATIONS WERE SOUTHERN PINE, 2.7 KSI CONCRETE AND CONCRETE MASONRY UNITS COMPLYING WITH ASTM C-90. GLAZING COMPLIES WITH ASTM E1300-04.

8) THE 1/3 STRESS INCREASE WAS NOT USED IN THIS ANCHOR EVALUATION. THE 1.6 LOAD DURATION FACTOR WAS USED FOR THE EVALUATION OF WOOD SCREWS.

9) IF THE EXACT PRODUCT SIZE IS NOT LISTED IN THE TABLES, ALWAYS ROUND UP TO THE NEXT LARGER VALUE.

ANCHOR LOCATIONS & SPACING

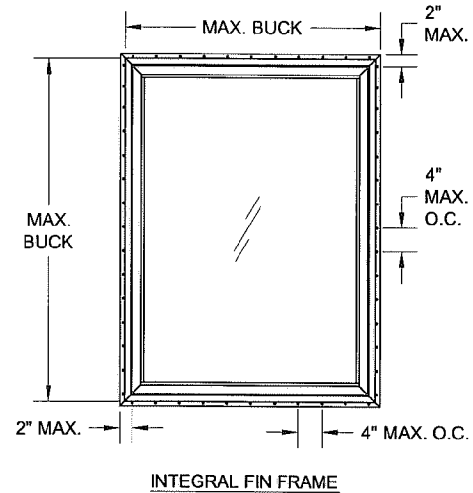
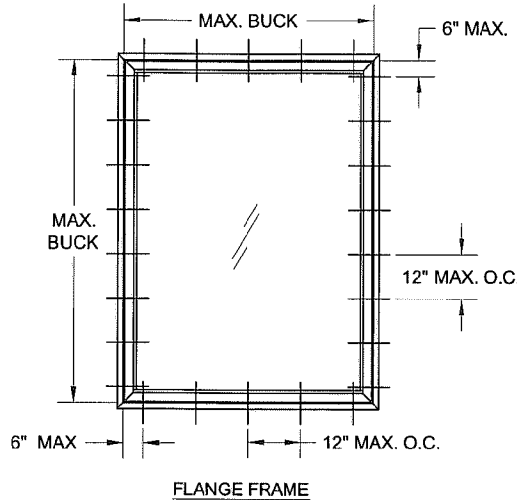

TABLE 2: ANCHORS FOR FLANGE WINDOWS

Anchor	Substrate	Min. Edge Distance	Min. Embedment
#10 Sheet Metal Screw, G5 Steel or 410 Stainless Steel	P.T. Southern Pine (SG = .55)	1/2"	1-3/8"
	Aluminum, 6063-T5 min.	3/8"	1/8"
	Steel Stud, Gr. 33 min.	3/8"	0.0346 (20 ga)
	A36 Steel	3/8"	1/8"
3/16" Steel Ultracon	P.T. Southern Pine (SG = .55)	1/2"	1-3/8"
	Concrete (min. 2.7 ksi)	1"	1"
	Ungrouted CMU, (ASTM C-90)	1"	1-1/4"

NOTE: FOR ALL METAL SUBSTRATES, SCREW EMBEDMENT SHALL BE MIN. 3 THREADS BEYOND INSIDE FACE OF MATERIAL.

TABLE 3: ANCHORS FOR FIN WINDOWS

Anchor	Substrate	Min. Edge Distance	Min. Embedment
2-1/2" x .113" Box Nail	P.T. Southern Pine (SG = .55)	5/16"	2-7/16"
2-1/2" x .131" Common Nail	P.T. Southern Pine (SG = .55)	3/8"	2-7/16"
2-1/2" x .145" Roofing Nail	P.T. Southern Pine (SG = .55)	3/8"	2-7/16"
#10 Steel SMS	P.T. Southern Pine (SG = .55)	1/2"	1-3/8"
	Aluminum, 6063-T5 min.	3/8"	1/8"
	Steel Stud, Gr. 33 min.	3/8"	0.0346 (20 ga)
	A36 Steel	3/8"	1/8"

NOTE: FOR ALL METAL SUBSTRATES, SCREW EMBEDMENT SHALL BE MIN. 3 THREADS BEYOND INSIDE FACE OF MATERIAL.

SHAPES MAY BE USED BY INSCRIBING THE SHAPE IN A BLOCK AND OBTAINING DESIGN PRESSURES FOR THAT BLOCK SIZE FROM THE TABLE ON THIS SHEET.

TABLE 1: AS TESTED

Window Buck Size		Design Pressure		Certification Numbers
Width	Height	(+) psf	(-) psf	
96"	60"	80	80	190-227, 474
75"	60"	70	70	190-228, 230, 475
48"	62"	75	75	190-232, 701

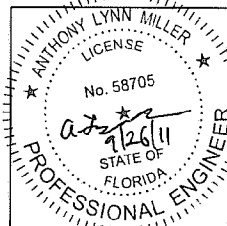

PGI
 1070 TECHNOLOGY DRIVE
 NOKOMIS, FL 34275
 FL CERT. OF AUTH.: 29296
 A. Lynn Miller, P.E.
 P.E. #58705

Drawn By: J. ROSOWSKI	Date: 07/10/11	Material: VINYL	THE INFORMATION, DESIGN OR DATA CONTAINED HEREIN IS THE EXCLUSIVE PROPERTY OF PGT INDUSTRIES AND CONSIDERED CONFIDENTIAL AND PROPRIETARY. NO PORTION OF THIS DOCUMENT MAY BE USED OR REPRODUCED IN ANY FORM WITHOUT THE EXPRESSED WRITTEN PERMISSION OF PGT INDUSTRIES.
Revised By:	Date:	Revisions:	
Description: Title: PICTURE WINDOW			
Series/Model: PW-520	Scale: NTS	Sheet: 1 of 3	Drawing No. 3071011JR
			Rev.

INSTALLATION WITH FLANGE FRAME

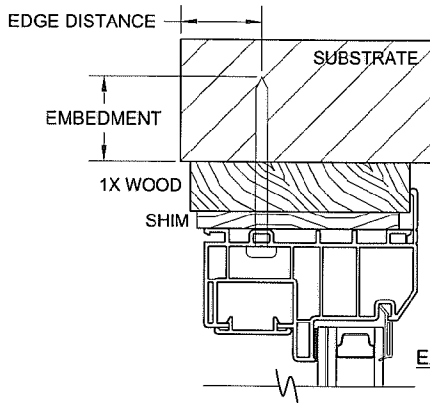

FLANGE FRAME,
HEAD INSTALLATION
(USING 1X BUCKSTRIP)

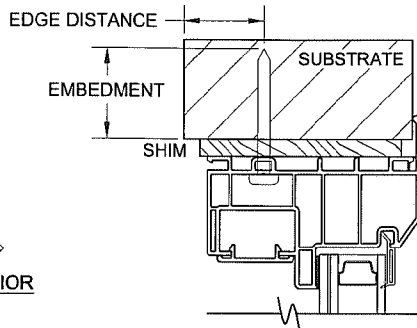

FLANGE FRAME,
HEAD INSTALLATION
(DIRECTLY TO SUBSTRATE)

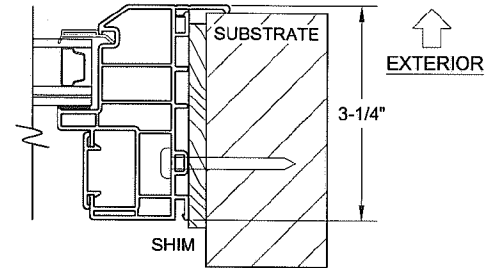

FLANGE FRAME,
JAMB INSTALLATION
(DIRECTLY TO SUBSTRATE)

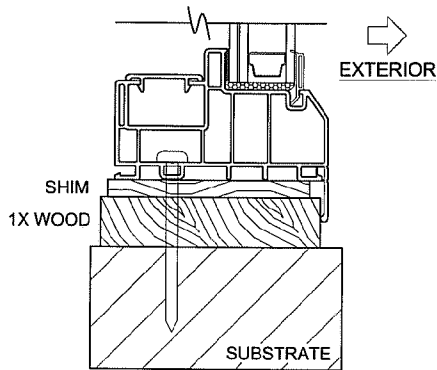

FLANGE FRAME,
SILL INSTALLATION
(USING 1X BUCKSTRIP)

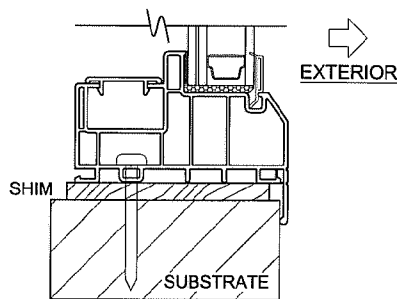

FLANGE FRAME,
SILL INSTALLATION
(DIRECTLY TO SUBSTRATE)

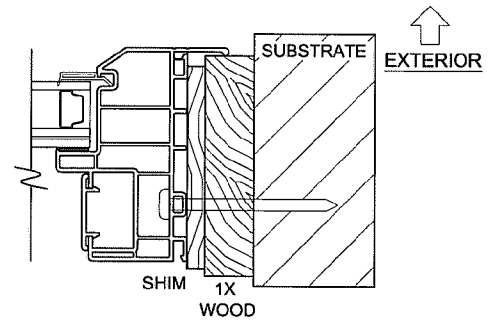

FLANGE FRAME,
JAMB INSTALLATION
(USING 1X BUCKSTRIP)

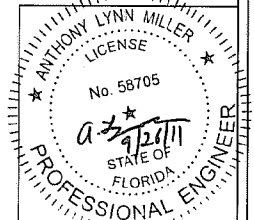

INSTALLATION NOTES:

- 1) SEE SHEET 1 FOR SPACING REQUIREMENTS.
- 2) SEE TABLE(S) ON SHEET 1 FOR ANCHORAGE AND SUBSTRATE REQUIREMENTS.
- 3) MAX. SHIM THICKNESS TO BE 1/4".
- 4) GLASS SHOWN IS FOR ILLUSTRATIVE PURPOSES ONLY AND MAY DIFFER TO MEET DESIGN REQUIREMENTS.
- 5) FLANGE MAY BE REMOVED FOR EQUAL-LEG FRAME APPLICATIONS. USE FLANGE INSTRUCTIONS.

 1070 TECHNOLOGY DRIVE NOKOMIS, FL 34275 FL CERT. OF AUTH.: 29296	Drawn By: J. ROSOWSKI	Date: 07/10/11	Material: VINYL	THE INFORMATION, DESIGN OR DATA CONTAINED HEREIN IS THE EXCLUSIVE PROPERTY OF PGT INDUSTRIES AND CONSIDERED CONFIDENTIAL AND PROPRIETARY. NO PORTION OF THIS DOCUMENT MAY BE USED OR REPRODUCED IN ANY FORM WITHOUT THE EXPRESSED WRITTEN PERMISSION OF PGT INDUSTRIES.
	Revised By:	Date:	Revisions:	
Description:				
Title: PICTURE WINDOW				
A. Lynn Miller, P.E. P.E. #58705	Series/Model: PW-520	Scale: NTS	Sheet: 2 of 3	Drawing No. 3071011JR

INSTALLATION WITH FIN FRAME

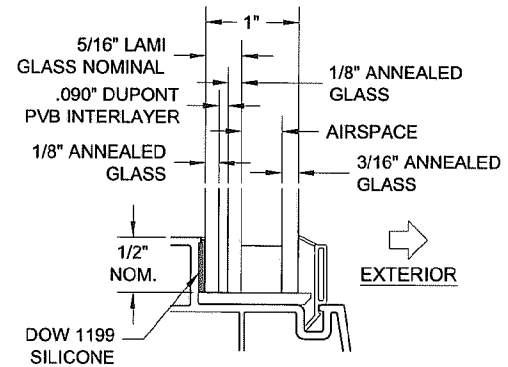
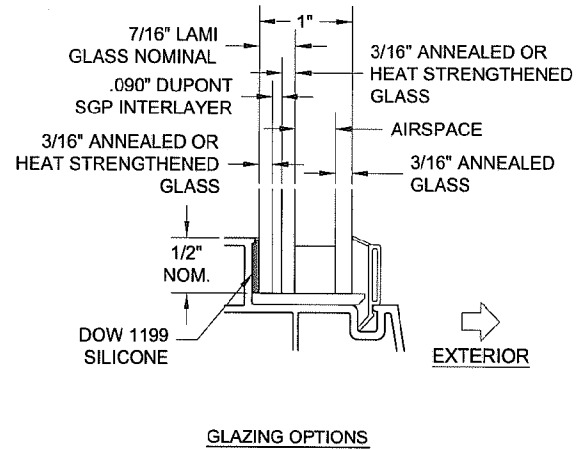
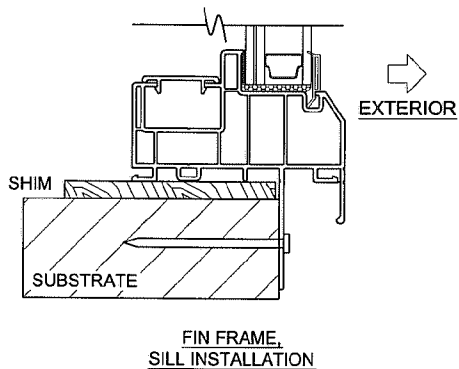
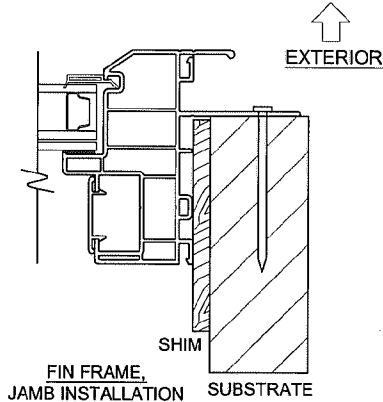
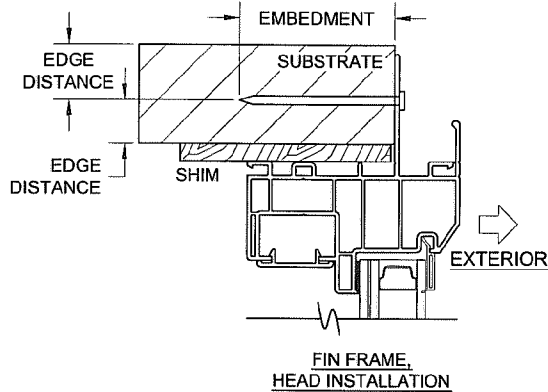

INSTALLATION NOTES:

- 1) SEE SHEET 1 FOR SPACING REQUIREMENTS.
- 2) SEE TABLE(S) ON SHEET 1 FOR ANCHORAGE AND SUBSTRATE REQUIREMENTS.
- 3) MAX. SHIM THICKNESS TO BE 1/4".
- 4) GLASS SHOWN IS FOR ILLUSTRATIVE PURPOSES ONLY AND MAY DIFFER TO MEET DESIGN REQUIREMENTS.
- 5) FIN AND FLANGE MAY BE REMOVED FOR EQUAL-LEG FRAME APPLICATIONS, USE FLANGE INSTRUCTIONS ON SHEET 2.

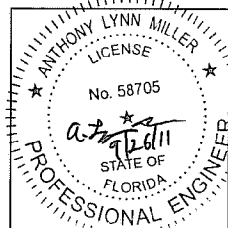

PGI

3070 TECHNOLOGY DRIVE
NOKOMIS, FL 34275
FL CERT. OF AUTH.: 29296

A. Lynn Miller, P.E.
P.E. #58705

Drawn By: J. ROSOWSKI	Date: 07/10/11	Material: VINYL	THE INFORMATION, DESIGN OR DATA CONTAINED HEREIN IS THE EXCLUSIVE PROPERTY OF PGT INDUSTRIES AND CONSIDERED CONFIDENTIAL AND PROPRIETARY. NO PORTION OF THIS DOCUMENT MAY BE USED OR REPRODUCED IN ANY FORM WITHOUT THE EXPRESSED WRITTEN PERMISSION OF PGT INDUSTRIES.
Revised By:	Date:	Revisions:	
Description: Title: PICTURE WINDOW			
Series/Model: PW-520	Scale: NTS	Sheet: 3 of 3	Drawing No. 3071011JR
Rev:			