



DEPARTMENT OF PERMITTING, ENVIRONMENT, AND REGULATORY  
AFFAIRS (PERA)  
BOARD AND CODE ADMINISTRATION DIVISION

MIAMI-DADE COUNTY, FLORIDA  
PRODUCT CONTROL SECTION  
11805 SW 26<sup>th</sup> Street, Room 208  
Miami, Florida 33175-2474  
T (786) 315-2590 F (786) 315-2599

**NOTICE OF ACCEPTANCE (NOA)**

[www.miamidade.gov/pera/](http://www.miamidade.gov/pera/)

**PGT Industries, Inc.**  
**1070 Technology Drive**  
**North Venice, FL 34275**

**SCOPE:**

This NOA is being issued under the applicable rules and regulations governing the use of construction materials. The documentation submitted has been reviewed and accepted by Miami-Dade County PERA -Product Control Section to be used in Miami-Dade County and other areas where allowed by the Authority Having Jurisdiction (AHJ).

This NOA shall not be valid after the expiration date stated below. The Miami-Dade County Product Control Section (In Miami-Dade County) and/ or the AHJ (in areas other than Miami-Dade County) reserve the right to have this product or material tested for quality assurance purposes. If this product or material fails to perform in the accepted manner, the manufacturer will incur the expense of such testing and the AHJ may immediately revoke, modify, or suspend the use of such product or material within their jurisdiction. PERA reserves the right to revoke this acceptance, if it is determined by Miami-Dade County Product Control Section that this product or material fails to meet the requirements of the applicable building code. This product is approved as described herein, and has been designed to comply with the Florida Building Code, including the High Velocity Hurricane Zone.

**DESCRIPTION: Series "PW's-2720/ 2820 Vinyl" White PVC Fixed Window - L.M.I.**

**APPROVAL DOCUMENT:** Drawing No. **08-00885** titled "Series PW 2720 PVC Fixed Window Impact & PW 2820 PVC Fixed Window Impact", sheets 1 through 7 of 7, prepared by manufacturer, dated 08/04/08 with the latest revision "C" dated 10/27/11, prepared by PGT Industries, Inc., signed and sealed by Anthony Lynn Miller, P. E., bearing the Miami-Dade County Product Control Revision stamp with the Notice of Acceptance number and Expiration date by the Miami-Dade County Product Control Section.

**MISSILE IMPACT RATING: Large and Small Missile Impact Resistant.**

**LABELING:** Each unit shall bear a permanent label with the manufacturer's name or logo, city, state, model/ series and following statement: "Miami-Dade County Product Control Approved" unless otherwise noted herein.

**RENEWAL** of this NOA shall be considered after a renewal application has been filed and there has been no change in the applicable building code negatively affecting the performance of this product.

**TERMINATION** of this NOA will occur after the expiration date or if there has been a revision or change in the materials, use, and/or manufacture of the product or process. Misuse of this NOA as an endorsement of any product, for sales, advertising or any other purposes shall automatically terminate this NOA. Failure to comply with any section of this NOA shall be cause for termination and removal of NOA.

**ADVERTISEMENT:** The NOA number preceded by the words Miami-Dade County, Florida, and followed by the expiration date may be displayed in advertising literature. If any portion of the NOA is displayed, then it shall be done in its entirety.

**INSPECTION:** A copy of this entire NOA shall be provided to the user by the manufacturer or its distributors and shall be available for inspection at the job site at the request of the Building Official.

This NOA **revises NOA No. 09-1104.02** and consists of this page 1, evidence pages E-1 and E-2, as well as approval document mentioned above.

The submitted documentation was reviewed by **Jaime D. Gascon, P. E.**



*J. Gascon*  
*2/9/12*

NOA No. 11-1114.19  
Expiration Date: August 11, 2015  
Approval Date: February 16, 2012  
Page 1

**NOTICE OF ACCEPTANCE: EVIDENCE SUBMITTED**

**A. DRAWINGS**

1. Manufacturer's die drawings and sections.  
*(Submitted under NOA's No. 09-1104.02)*
2. Drawing No. **08-00885** titled "Series PW 2720 PVC Fixed Window Impact & PW 2820 PVC Fixed Window Impact", sheets 1 through 7 of 7, prepared by manufacturer, dated 08/04/08 with the latest revision "C" dated 10/27/11, prepared by PGT Industries, Inc., signed and sealed by Anthony Lynn Miller, P. E.

**B. TESTS**

1. Test reports on:
  - 1) Air Infiltration Test, per FBC, TAS 202-94
  - 2) Uniform Static Air Pressure Test, Loading per FBC TAS 202-94
  - 3) Water Resistance Test, per FBC, TAS 202-94
  - 4) Large Missile Impact Test per FBC, TAS 201-94
  - 5) Cyclic Wind Pressure Loading per FBC, TAS 203-94

Along with marked-up drawings and installation diagram of a PVC fixed window, prepared by NCTL **210-3642-1**, NCTL **210-3642-2**, NCTL **210-3636-1**, NCTL **210-3636-2** and NCTL **210-3635-1**, dated 09/17/09, all signed and sealed by Gerard J. Ferrara, P. E.

*(Submitted under NOA No. 09-1104.02)*

**C. CALCULATIONS**

1. Anchor verification calculations and structural analysis, complying with FBC-2007, prepared by PGT Industries, Inc., dated 07/15/210, signed and sealed by Luis R. Lomas, P. E.  
*(Submitted under previous NOA No. 09-1104.02)*
2. **Complies with ASTM E1300-02/ 04**

**D. QUALITY ASSURANCE**

1. Miami-Dade Department of Permitting, Environment, and Regulatory Affairs (PERA)

**E. MATERIAL CERTIFICATIONS**

1. Notice of Acceptance No. **11-0624.01** issued to **E.I. DuPont DeNemours & Co., Inc.** for their "**DuPont Butacite® PVB Interlayer**" dated 09/08/11, expiring on 12/11/16.
2. Notice of Acceptance No. **11-0624.02** issued to **E.I. DuPont DeNemours & Co., Inc.** for their "**DuPont SentryGlas® Interlayer**" dated 08/25/11, expiring on 01/14/17.

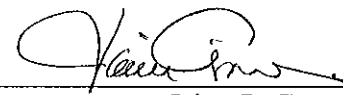

**Jaime D. Gascon, P. E.**  
**Product Control Section Supervisor**  
**NOA No. 11-1114.19**  
**Expiration Date: August 11, 2015**  
**Approval Date: February 16, 2012**

**NOTICE OF ACCEPTANCE: EVIDENCE SUBMITTED**

**E. MATERIAL CERTIFICATIONS (CONTINUED)**

3. Notice of Acceptance No. **11-0830.09** issued to Mikron Industries, Inc., for their "**White Rigid PVC Exterior Extrusions for Windows and Doors**" dated 10/6/11, expiring on 12/26/16.

**F. STATEMENTS**

1. Statement letter of conformance and compliance with the FBC-2007 (with the 2009 supplement) and FBC-2010, dated 10/29/11, signed and sealed by Anthony Lynn Miller, P. E.
2. Statement letter of no financial interest and independence, dated 10/29/11, signed and sealed by Anthony Lynn Miller, P. E.
3. Letter of *Adoption of as his Own, the Work of another Engineer* per Section 61G15-27.001 of the F.B.P.E., dated 10/07/11 signed and sealed by Anthony Lynn Miller, P. E.
4. Statement letter of no financial interest, independence, conformance and compliance with the FBC-2007, dated 10/21/09, signed and sealed by Luis R. Lomas, P. E.  
*(Submitted under previous NOA No. 09-1104.02)*
5. Laboratory addendum letter for Test Reports No. **NCTL 210-3635-1** issued by National Certified Testing Laboratories, Inc., dated 04/06/10, signed and sealed by Gerard J. Ferrara, P. E.  
*(Submitted under previous NOA No. 09-1104.02)*
6. Laboratory compliance letter for Test Reports No.'s **NCTL 210-3642-1**, **NCTL 210-3642-2**, **NCTL 210-3636-1**, **NCTL 210-3636-2** and **NCTL 210-3635-1**, issued by National Certified Testing Laboratories, Inc., dated 09/17/09, signed and sealed by Gerard J. Ferrara, P. E.  
*(Submitted under previous NOA No. 09-1104.02)*

**G. OTHERS**

1. Notice of Acceptance No. **09-1104.02**, issued to PGT Industries, Inc. for their Series "PW-2720/ 2820" White PVC Fixed Window - L.M.I.", approved on 08/11/10 and expiring on 08/11/15.

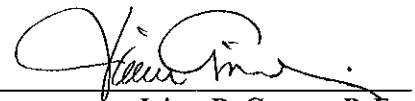

**Jaime D. Gascon, P. E.**  
**Product Control Section Supervisor**  
**NOA No. 11-1114.19**

**Expiration Date: August 11, 2015**  
**Approval Date: February 16, 2012**

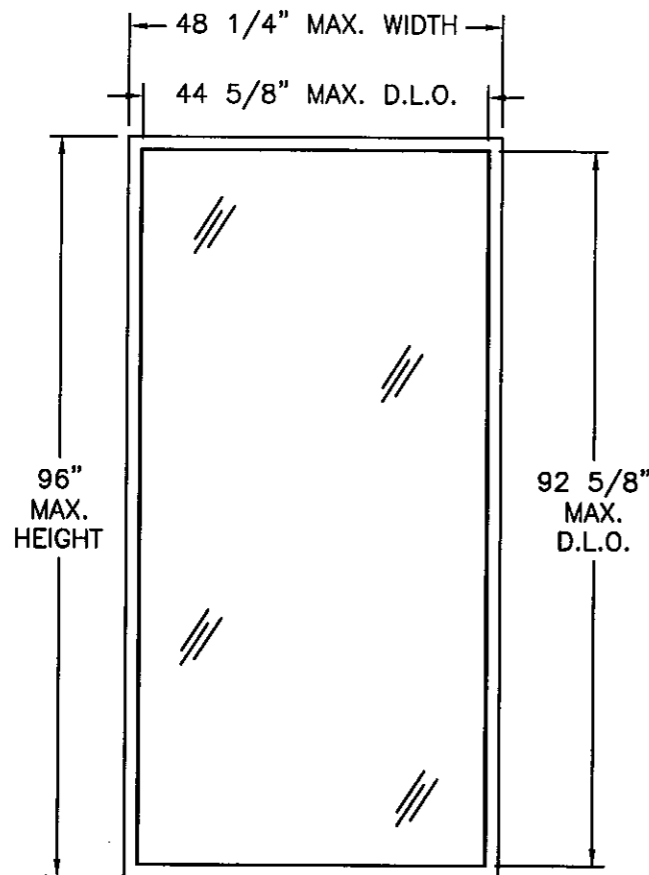

**PW2720 AND PW2820  
PVC FIXED WINDOW**  
48 1/4" x 96"  
EXTERIOR VIEW

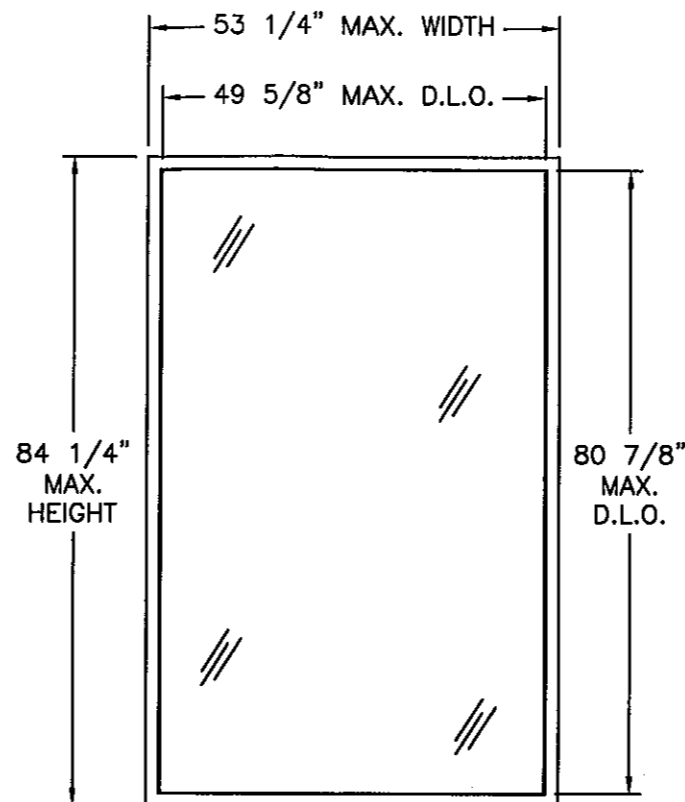

**PW2720 AND PW2820  
PVC FIXED WINDOW**  
53 1/4" x 84 1/4"  
EXTERIOR VIEW

**PW2720 WITH GLAZING TYPES C AND D**

DESIGN PRESSURE RATING	IMPACT RATING
+ 65.0 PSF -80.0 PSF	LARGE AND SMALL MISSILE IMPACT

**PW2820 WITH GLAZING TYPES A AND B**

DESIGN PRESSURE RATING	IMPACT RATING
+ 100.0 PSF -120.0 PSF	LARGE AND SMALL MISSILE IMPACT

REVISIONS			
REV	DESCRIPTION	DATE	APPROVED
A	PER DADE LETTER DATED 2-4-10	03/25/10	R.L.
B	ADDED "WHITE" TO ALL PVC	07/08/10	R.L.
C	2010 FBC UPDATE	10/27/11	J.J.

**NOTES:**

- 1) THE PRODUCT SHOWN HEREIN IS DESIGNED AND MANUFACTURED TO COMPLY WITH REQUIREMENTS OF THE FLORIDA BUILDING CODE.
- 2) WOOD FRAMING AND MASONRY OPENING TO BE DESIGNED AND ANCHORED TO PROPERLY TRANSFER ALL LOADS TO STRUCTURE. FRAMING AND MASONRY OPENING IS THE RESPONSIBILITY OF THE ARCHITECT OR ENGINEER OF RECORD.
- 3) UNITS MUST BE GLAZED PER ASTM E1300 SEE SHEET 7 FOR APPROVED GLASS TYPES.
- 4) APPROVED IMPACT PROTECTIVE SYSTEM IS NOT REQUIRED FOR THIS PRODUCT IN WIND-BORNE DEBRIS REGIONS.
- 5) INSTALLATION ANCHORS SHALL BE INSTALLED IN ACCORDANCE WITH ANCHOR MANUFACTURER'S INSTALLATION INSTRUCTIONS, AND ANCHORS SHALL NOT BE USED IN SUBSTRATES WITH STRENGTHS LESS THAN THE MINIMUM STRENGTH SPECIFIED BELOW:
  - A. WOOD - MINIMUM SPECIFIC GRAVITY OF G=0.42
  - B. CONCRETE - MINIMUM COMPRESSIVE STRENGTH OF 3,200 PSI.
  - C. MASONRY - STRENGTH CONFORMANCE TO ASTM C-90, GRADE N, TYPE 1 (OR GREATER).
  - D. METAL FRAMING - 16GA (.060) MINIMUM THICKNESS
- 6) ALLOWABLE STRESS INCREASE OF 1/3 WAS NOT USED IN THE DESIGN OF THE PRODUCT SHOWN HEREIN. WIND LOAD DURATION FACTOR Cd=1.6 WAS USED FOR WOOD ANCHOR CALCULATIONS.
- 7) FRAME MATERIAL: EXTRUDED WHITE RIGID PVC .108" THICK.
- 8) PW2720 UNITS ARE GLAZED WITH BUTACITE PVB INTERLAYER, GLAZING TYPES C AND D. PW2820 UNITS ARE GLAZED WITH SENTRY GLASPLUS INTERLAYER, GLAZING TYPES A AND B. ALL OTHER COMPONENTS IN PW2720 AND PW2820 ARE THE SAME.

TABLE OF CONTENTS	
SHEET NO.	DESCRIPTION
1	ELEVATION AND NOTES
2	ELEVATION AND DESIGN PRESSURE CHART
3	ANCHORING AND NOTES
4	BILL OF MATERIALS AND CROSS SECTIONS
5 - 6	INSTALLATION DETAILS
7	GLAZING DETAILS AND COMPONENTS

PRODUCT REVISED  
as complying with the Florida  
Building Code 11-114.19  
Acceptance No. 28/11/2015  
By *[Signature]*  
Miami Dade Product Control

**PGT INDUSTRIES**  
1070 TECHNOLOGY DRIVE  
NOKOMIS, FL 3275

PW2720 PVC FIXED WINDOW IMPACT  
PW2820 PVC FIXED WINDOW IMPACT  
ELEVATION AND NOTES

DRAWN: TJH DWG NO. 08-00885 REV C

SCALE NTS DATE 10/21/09 SHEET 1 OF 7

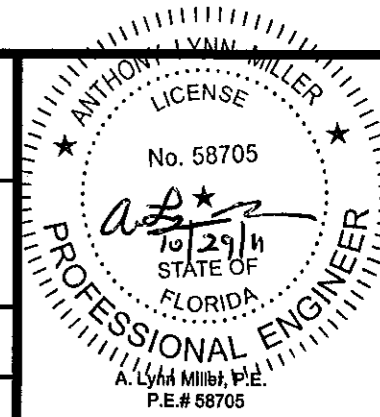

REVISIONS			
REV	DESCRIPTION	DATE	APPROVED
A	PER DADE LETTER DATED 2-4-10	03/25/10	R.L.
C	NO CHANGE THIS SHEET	10/27/11	J.J.

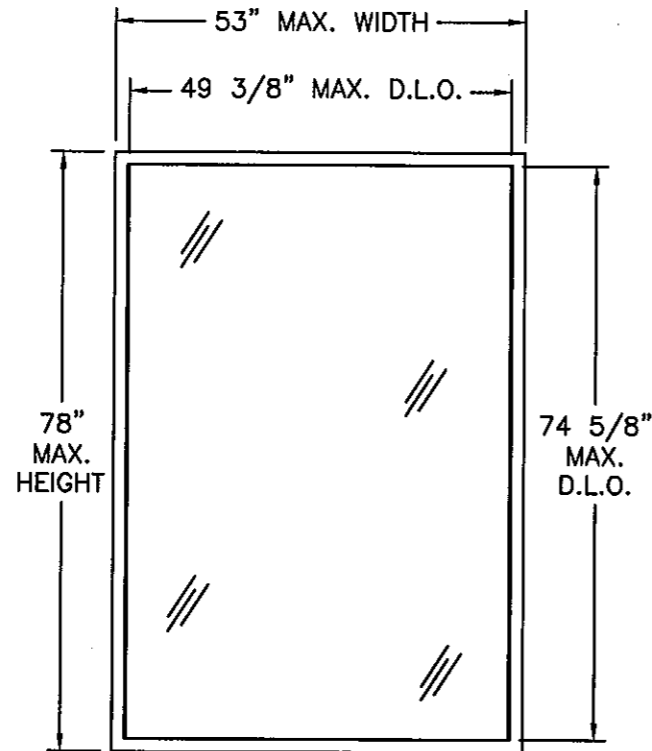

**PW2820 PVC FIXED WINDOW**  
53" x 78"  
EXTERIOR VIEW

PW2820 WITH GLAZING TYPE B

DESIGN PRESSURE RATING	IMPACT RATING
±120PSF	LARGE AND SMALL MISSILE IMPACT

**Maximum design pressure capacity chart**

Height (in)	Panel width (in)												
	24.0		30.0		36.0		42.0		48.0		53.0		
	Pos	Neg	Pos	Neg	Pos	Neg	Pos	Neg	Pos	Neg	Pos	Neg	
24.0	150.0	150.0	150.0	150.0	150.0	150.0	150.0	150.0	150.0	150.0	150.0	150.0	150.0
30.0	150.0	150.0	150.0	150.0	150.0	150.0	150.0	150.0	150.0	150.0	150.0	150.0	150.0
36.0	150.0	150.0	150.0	150.0	150.0	150.0	150.0	150.0	150.0	150.0	150.0	150.0	150.0
42.0	150.0	150.0	150.0	150.0	150.0	150.0	150.0	150.0	150.0	150.0	150.0	150.0	150.0
48.0	150.0	150.0	150.0	150.0	150.0	150.0	150.0	150.0	150.0	150.0	150.0	150.0	150.0
54.0	150.0	150.0	150.0	150.0	150.0	150.0	150.0	150.0	150.0	150.0	150.0	150.0	150.0
60.0	150.0	150.0	150.0	150.0	150.0	150.0	150.0	150.0	150.0	145.8	145.8	141.9	141.9
66.0	150.0	150.0	150.0	150.0	150.0	150.0	150.0	146.6	146.6	137.5	137.5	132.4	132.4
72.0	150.0	150.0	150.0	150.0	150.0	150.0	150.0	141.2	141.2	131.2	131.2	125.4	125.4
78.0	150.0	150.0	150.0	150.0	150.0	150.0	150.0	136.8	136.8	126.4	126.4	120.0	120.0

PRODUCT REVISED  
as complying with the Florida  
Building Code  
Acceptance No. 11-1114.19  
Expiration Date 08/11/2015  
By [Signature]  
Miami Dade Product Control

**PGT INDUSTRIES**  
1070 TECHNOLOGY DRIVE  
NOKOMIS, FL 3275

PW2720 PVC FIXED WINDOW IMPACT  
PW2820 PVC FIXED WINDOW IMPACT  
ELEVATION AND DESIGN PRESSURE CHART

DRAWN: TJH	DWG NO. 08-00885	REV C
SCALE NTS	DATE 10/21/09	SHEET 2 OF 7

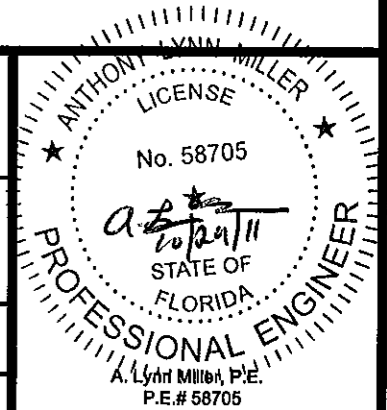

REVISIONS			
REV	DESCRIPTION	DATE	APPROVED
A	PER DADE LETTER DATED 2-4-10	03/25/10	R.L.
C	NO CHANGE THIS SHEET	10/27/11	J.J.

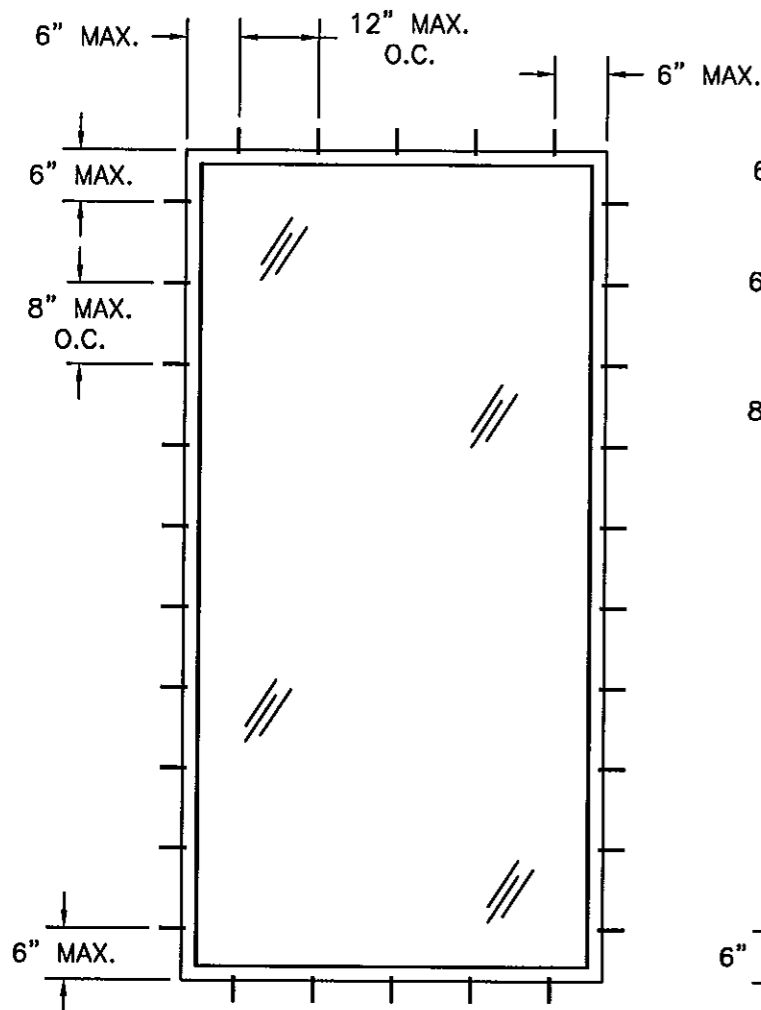

**PW2720 AND PW2820  
PVC FIXED WINDOW**  
48 1/4" x 96"  
EXTERIOR VIEW

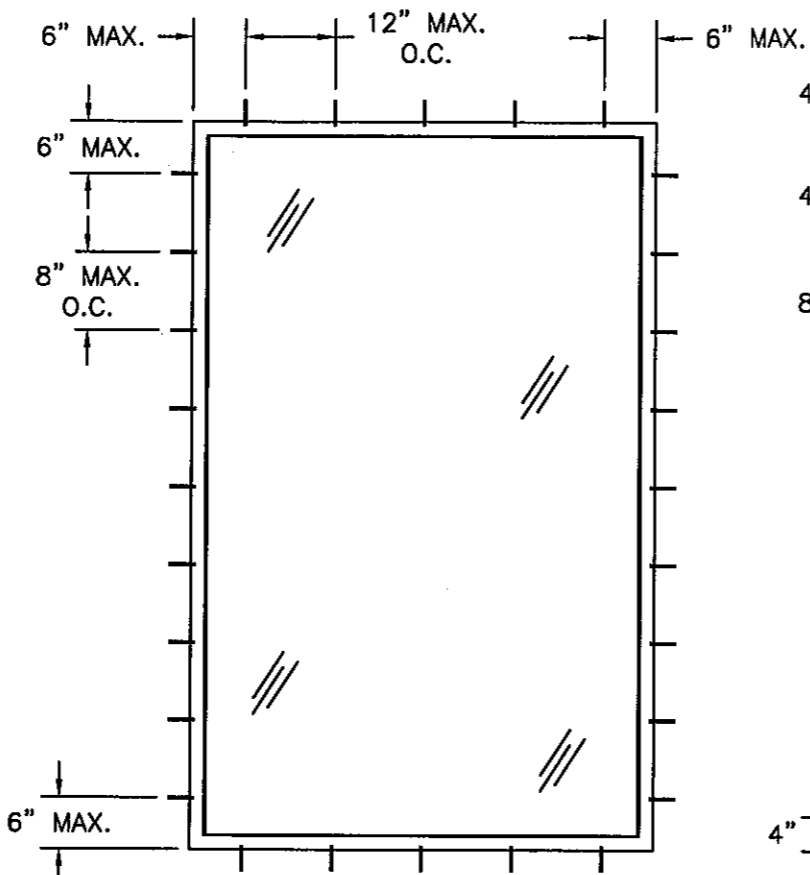

**PW2720 AND PW2820  
PVC FIXED WINDOW**  
53 1/4" x 84 1/4"  
EXTERIOR VIEW

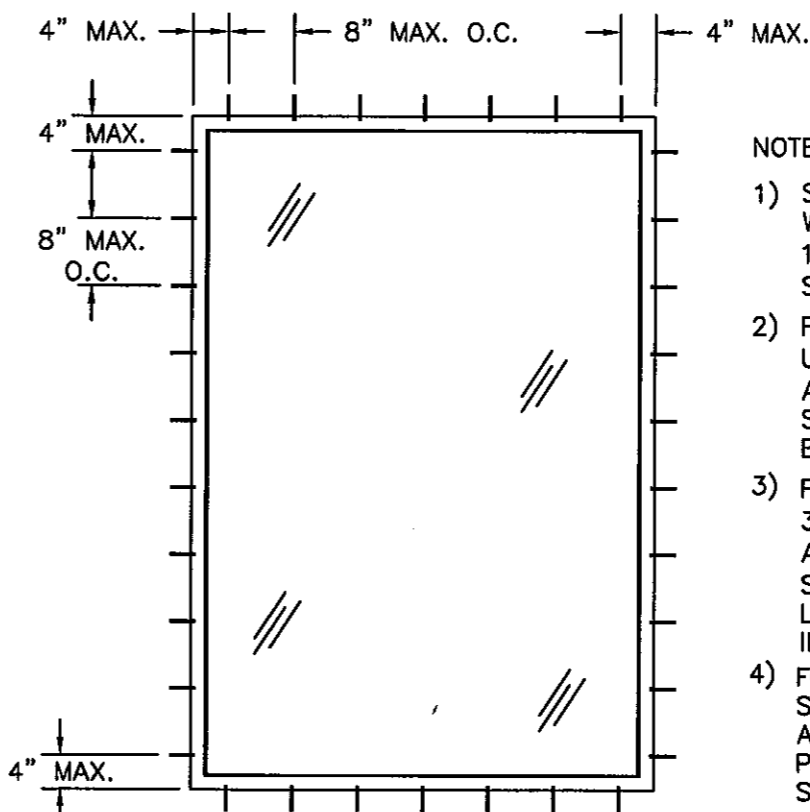

**PW2820 PVC FIXED WINDOW**  
53" x 78"  
EXTERIOR VIEW

**NOTES:**

- 1) SHIM AS REQUIRED AT EACH INSTALLATION ANCHOR WITH LOAD BEARING SHIM. SHIM WHERE SPACE OF 1/16" OR GREATER OCCURS. MAXIMUM ALLOWABLE SHIM STACK TO BE 1/4".
- 2) FOR INSTALLATION INTO WOOD FRAMING OR 2X BUCK USE #10 WOOD SCREW WITH SUFFICIENT LENGTH TO ACHIEVE A 1 3/8" MINIMUM EMBEDMENT INTO SUBSTRATE. LOCATE ANCHORS AS SHOWN IN ELEVATIONS AND INSTALLATION DETAILS.
- 3) FOR INSTALLATION INTO CONCRETE/MASONRY USE 3/16" ITW TAPCON WITH SUFFICIENT LENGTH TO ACHIEVE A 1 1/4" MINIMUM EMBEDMENT INTO SUBSTRATE WITH 2 5/8" MINIMUM EDGE DISTANCE. LOCATE ANCHORS AS SHOWN IN ELEVATIONS AND INSTALLATION DETAILS.
- 4) FOR ANCHORING INTO METAL FRAMING USE #10 TEK SELF TAPPING SCREWS WITH SUFFICIENT LENGTH TO ACHIEVE A MINIMUM EMBEDMENT OF THREE THREADS PAST THE FRAME THICKNESS. LOCATE ANCHORS AS SHOWN IN ELEVATIONS AND INSTALLATION DETAILS.
- 5) ALL FASTENERS TO BE CORROSION RESISTANT.

PRODUCT REVISED  
as complying with the Florida  
Building Code  
Acceptance No. 11-1114-19  
Expiration Date 08/11/2015  
By [Signature]  
Miami Dade Product Control

**PGT INDUSTRIES**  
1070 TECHNOLOGY DRIVE  
NOKOMIS, FL 34275

PW2720 PVC FIXED WINDOW IMPACT  
PW2820 PVC FIXED WINDOW IMPACT  
ANCHORING AND NOTES

DRAWN: TJH	DWG NO. 08-00885	REV C
SCALE NTS	DATE 10/21/09	SHEET 3 OF 7

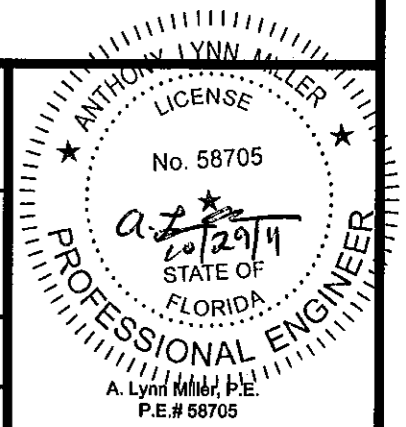

PARTS LIST				
NO.	PART NUMBER	DESCRIPTION	MANUFACTURER	MATERIAL
1	8304	FRAME HEAD, JAMB AND SILL	LB PLASTICS INC.	WHITE RIGID PVC
2	8345	PICTURE WINDOW COVER	LB PLASTICS INC.	WHITE RIGID PVC
3	8326	7/8" PLAIN BEAD	LB PLASTICS INC.	WHITE RIGID PVC
4	2NB-8K-038	RIGID FILLER 85 DUROMETER	FRANK LOWE	NEOPRENE
5	8343	FIN ADAPTER	LB PLASTICS INC.	WHITE RIGID PVC
6	SIKAFLEX 552	GLAZING COMPOUND	SIKA	POLYURETHANE
7		IMPACT GLAZING SEE SHEET 7		

REVISIONS			
REV	DESCRIPTION	DATE	APPROVED
A	PER DADE LETTER DATED 2-4-10	03/25/10	R.L.
C	NO CHANGE THIS SHEET	10/27/11	J.J.

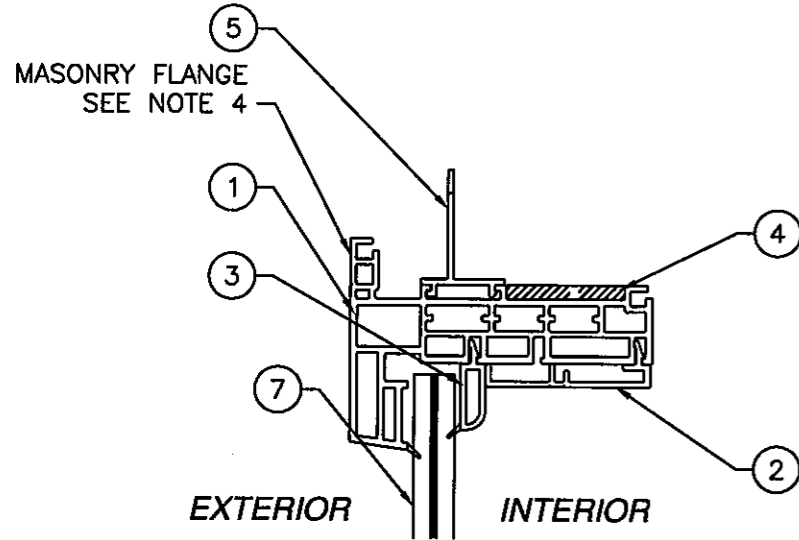

**VERTICAL CROSS SECTION  
W/FLANGE & FIN FRAME**  
HEAD SHOWN JAMBS & SILL SIMILAR

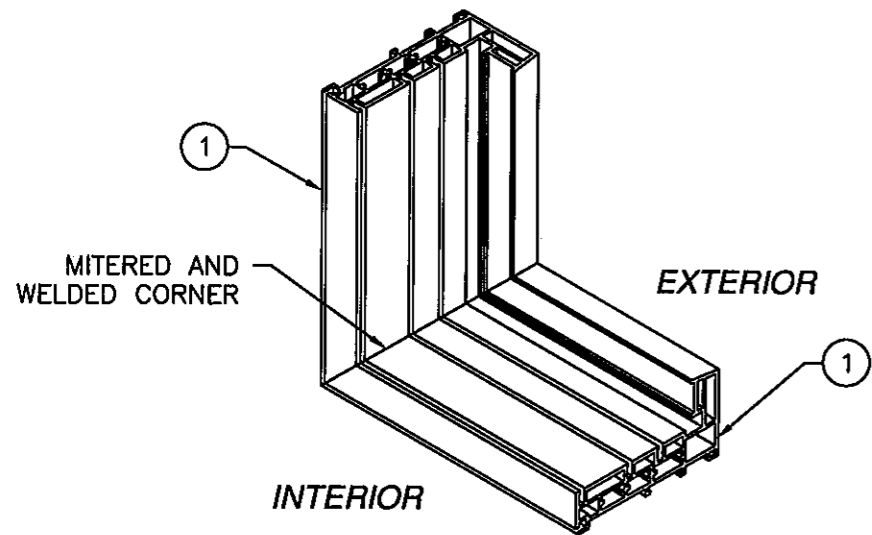

**FRAME CORNER CONSTRUCTION DETAIL**

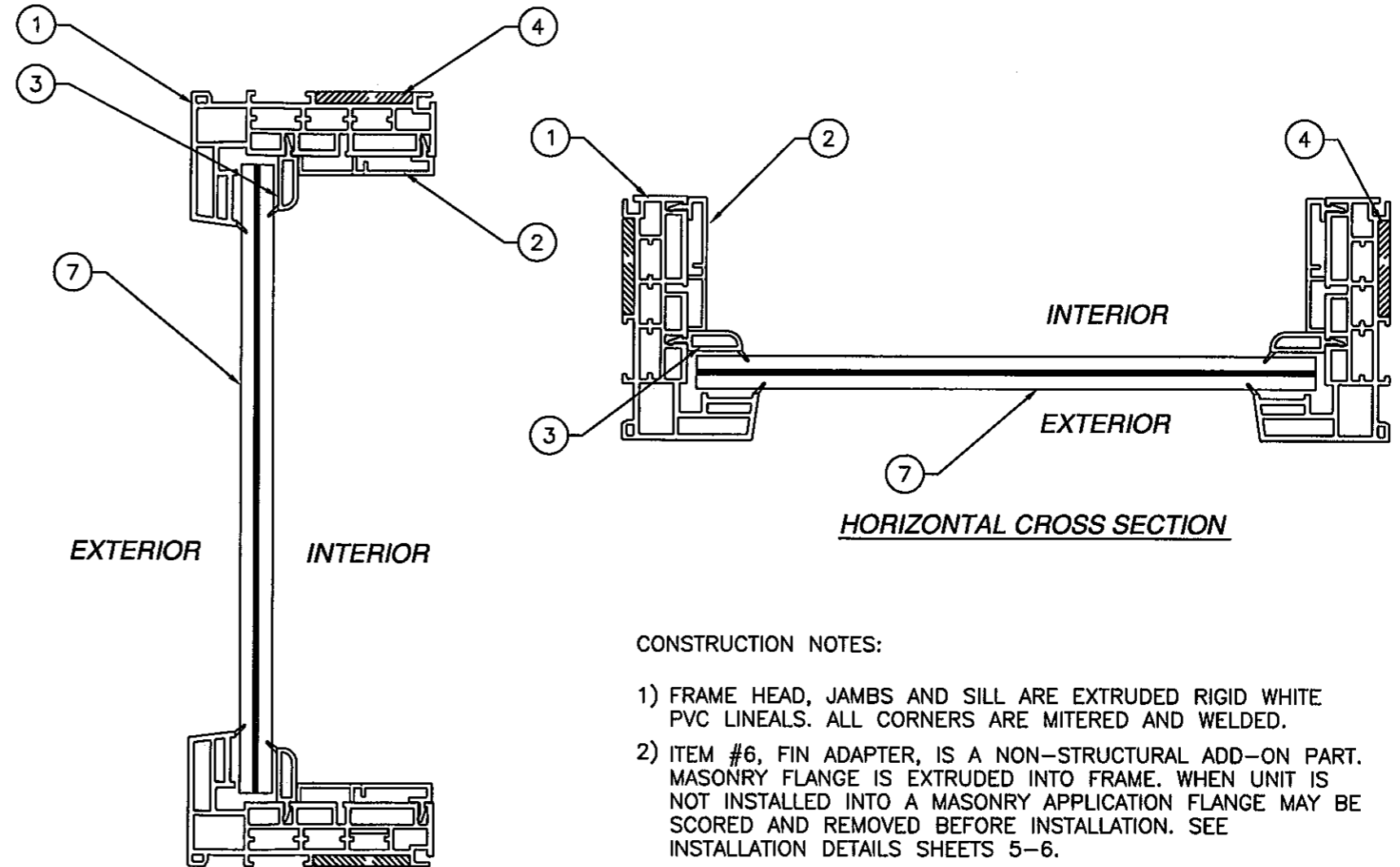

**HORIZONTAL CROSS SECTION**

**VERTICAL CROSS SECTION**

**CONSTRUCTION NOTES:**

- 1) FRAME HEAD, JAMBS AND SILL ARE EXTRUDED RIGID WHITE PVC LINEALS. ALL CORNERS ARE MITERED AND WELDED.
- 2) ITEM #6, FIN ADAPTER, IS A NON-STRUCTURAL ADD-ON PART. MASONRY FLANGE IS EXTRUDED INTO FRAME. WHEN UNIT IS NOT INSTALLED INTO A MASONRY APPLICATION FLANGE MAY BE SCORED AND REMOVED BEFORE INSTALLATION. SEE INSTALLATION DETAILS SHEETS 5-6.
- 3) WHITE PVC EXTRUSION TO BE LABELED WITH AAMA EXTRUDER CODE, EXTRUDER NAME, CITY, STATE AND MDCA

PRODUCT REVISED  
as complying with the Florida  
Building Code  
Acceptance No. **11-1114.19**  
Expiration Date **08/11/2015**  
By *[Signature]*  
Miami Dade Product Control

**PGT INDUSTRIES**  
1070 TECHNOLOGY DRIVE  
NOKOMIS, FL 34275

PW2720 PVC FIXED WINDOW IMPACT  
PW2820 PVC FIXED WINDOW IMPACT  
BILL OF MATERIALS AND CROSS SECTIONS

DRAWN: TJH	DWG NO. 08-00885	REV C
SCALE NTS	DATE 10/21/09	SHEET 4 OF 7

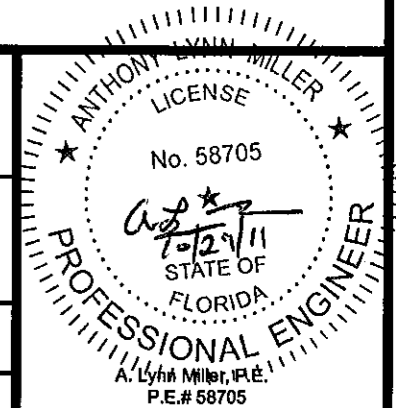

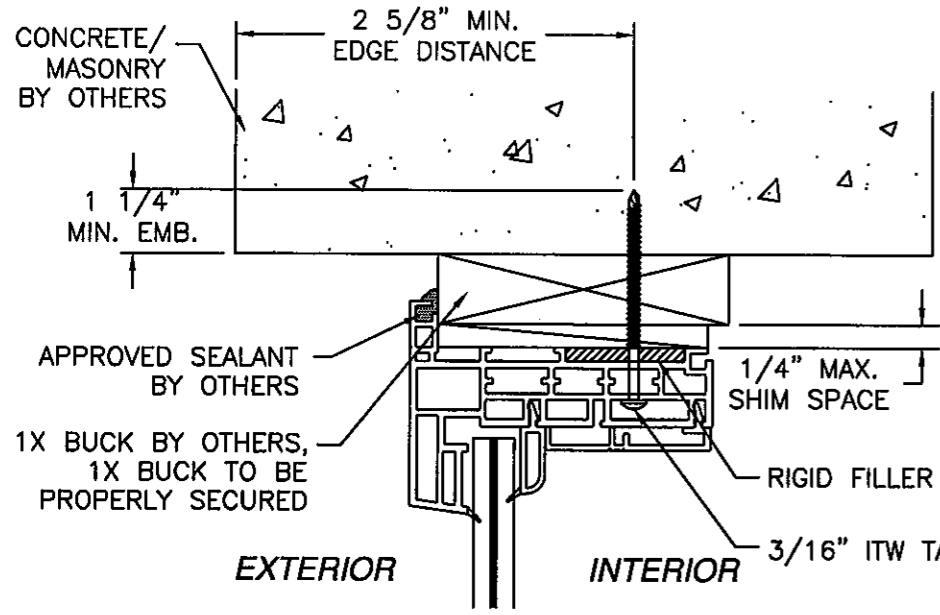

**HEAD**  
 CONCRETE/MASONRY FLANGE INSTALLATION  
 HEAD SHOWN, JAMBS AND SILL SIMILAR

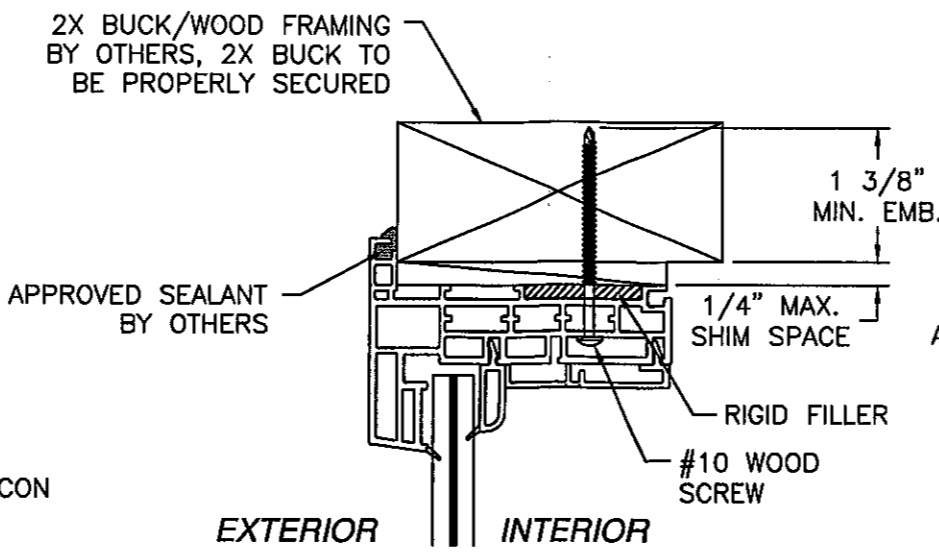

**HEAD**  
 WOOD FRAMING OR 2X BUCK FLANGE INSTALLATION  
 HEAD SHOWN, JAMBS AND SILL SIMILAR

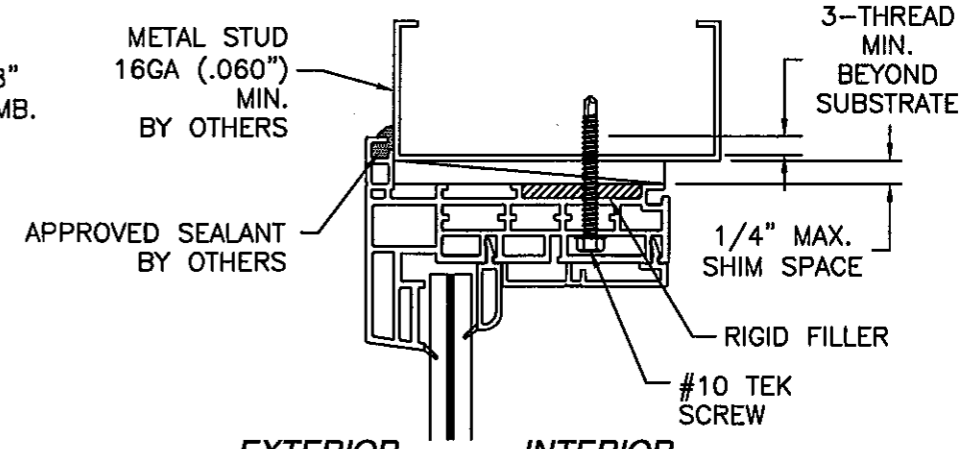

**HEAD**  
 METAL FRAMING FLANGE INSTALLATION  
 HEAD SHOWN, JAMBS AND SILL SIMILAR

REVISIONS			
REV	DESCRIPTION	DATE	APPROVED
A	PER DADE LETTER DATED 2-4-10	03/25/10	R.L.
C	NO CHANGE THIS SHEET	10/27/11	J.J.

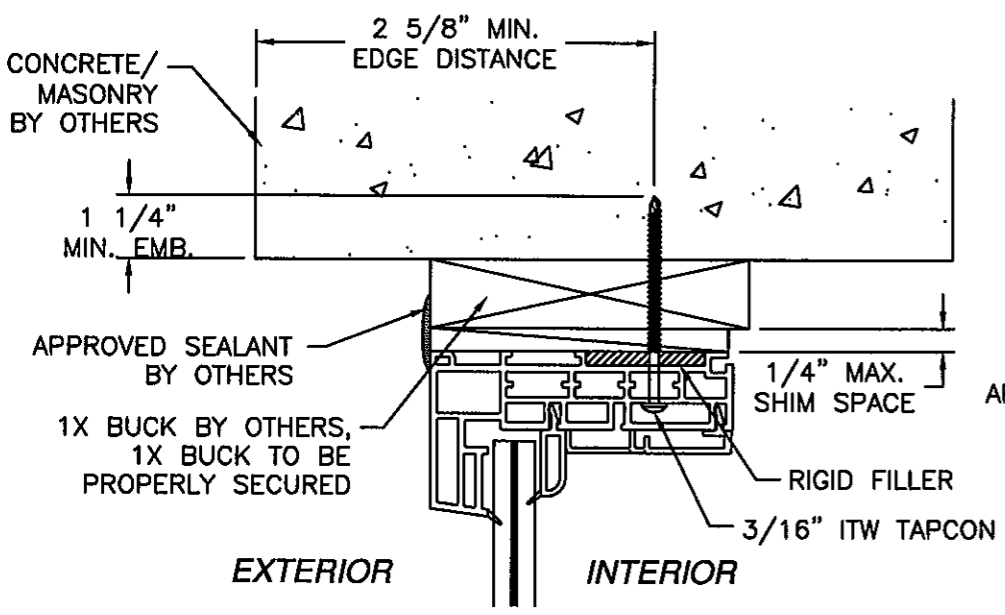

**HEAD**  
 CONCRETE/MASONRY BOX FRAME INSTALLATION  
 HEAD SHOWN, JAMBS AND SILL SIMILAR

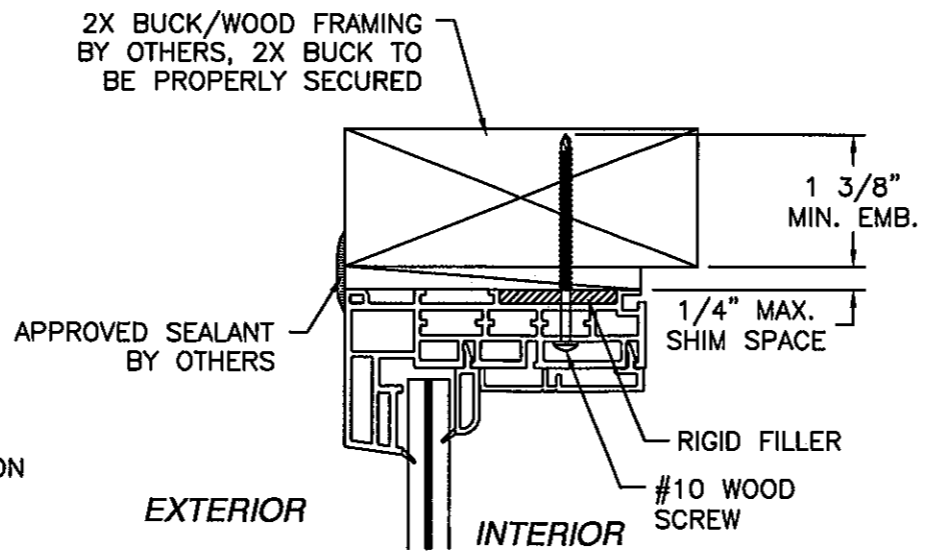

**HEAD**  
 WOOD FRAMING OR 2X BUCK BOX FRAME INSTALLATION  
 HEAD SHOWN, JAMBS AND SILL SIMILAR

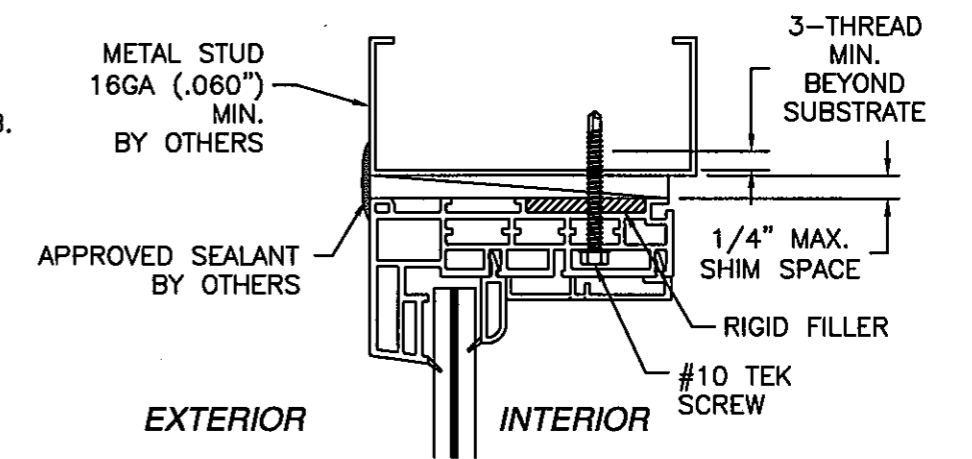

**HEAD**  
 METAL FRAMING BOX FRAME INSTALLATION  
 HEAD SHOWN, JAMBS AND SILL SIMILAR

PRODUCT REVISED  
 as complying with the Florida  
 Building Code  
 Acceptance No. 11-1114.19  
 Expiration Date 08/11/2015  
 By *[Signature]*  
 Miami Dade Product Control

**PGT INDUSTRIES**  
 1070 TECHNOLOGY DRIVE  
 NOKOMIS, FL 34275

PW2720 PVC FIXED WINDOW IMPACT  
 PW2820 PVC FIXED WINDOW IMPACT  
 INSTALLATION DETAILS

DRAWN: TJH	DWG NO. 08-00885	REV C
SCALE NTS	DATE 10/21/09	SHEET 5 OF 7

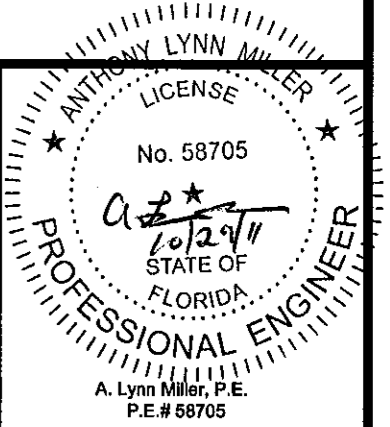



REVISIONS			
REV	DESCRIPTION	DATE	APPROVED
A	PER DADE LETTER DATED 2-4-10	03/25/10	R.L.
C	NO CHANGE THIS SHEET	10/27/11	J.J.

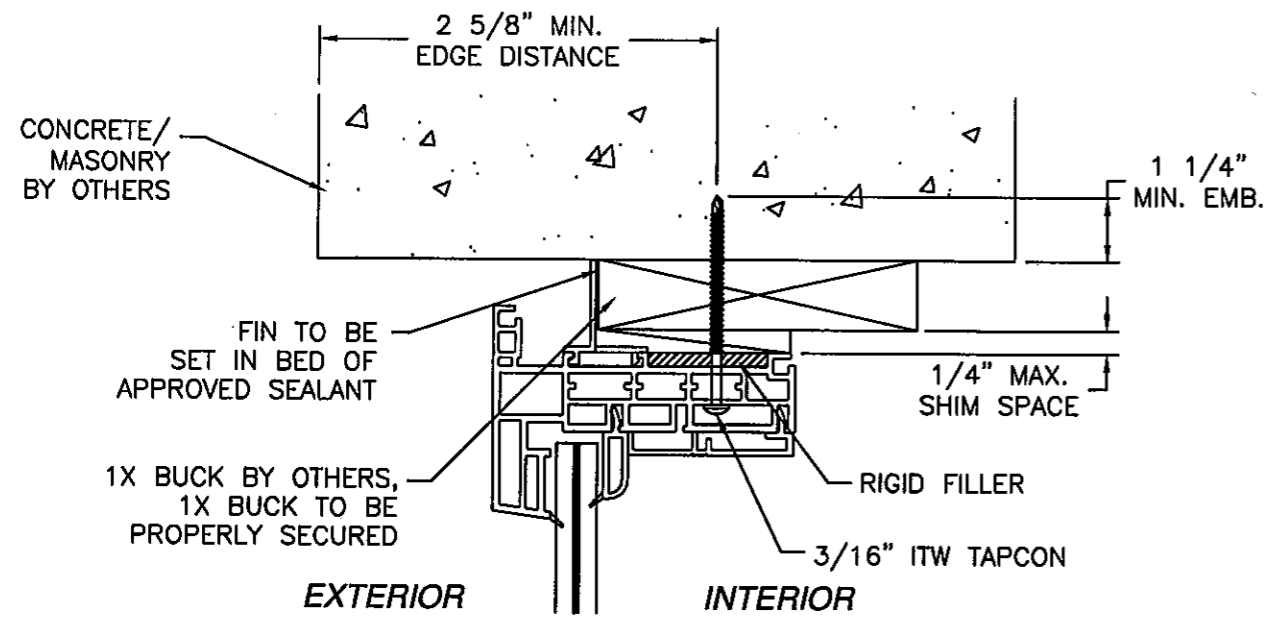

**HEAD**  
 CONCRETE/MASONRY FIN INSTALLATION  
 HEAD SHOWN, JAMBS AND SILL SIMILAR

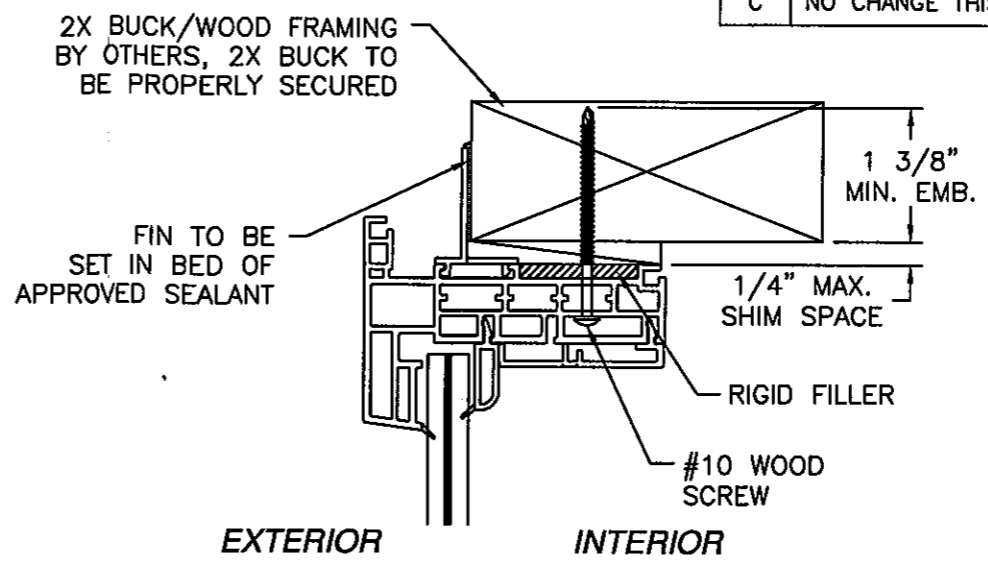

**HEAD**  
 WOOD FRAMING OR 2X BUCK FIN INSTALLATION  
 HEAD SHOWN, JAMBS AND SILL SIMILAR

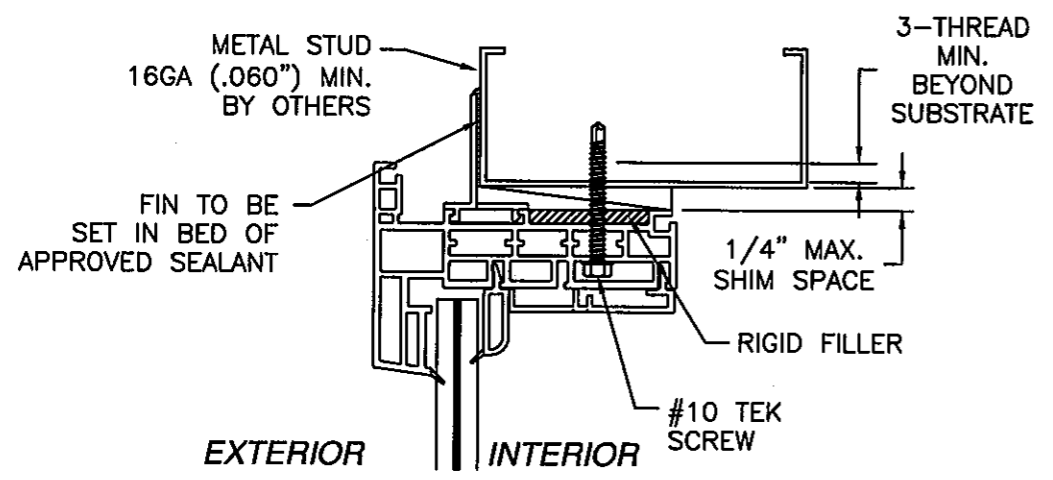

**HEAD**  
 METAL FRAMING FIN INSTALLATION  
 HEAD SHOWN, JAMBS AND SILL SIMILAR

PRODUCT REVISED  
 as complying with the Florida  
 Building Code  
 Acceptance No. 11-114.19  
 Expiration Date 08/11/2015  
 By [Signature]  
 Miami Dade Product Control

**PGT INDUSTRIES**  
 1070 TECHNOLOGY DRIVE  
 NOKOMIS, FL 34275

PW2720 PVC FIXED WINDOW IMPACT  
 PW2820 PVC FIXED WINDOW IMPACT  
 INSTALLATION DETAILS

DRAWN: TJH	DWG NO. 08-00885	REV C
SCALE NTS	DATE 10/21/09	SHEET 6 OF 7

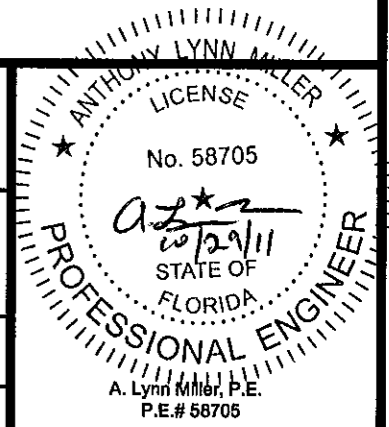

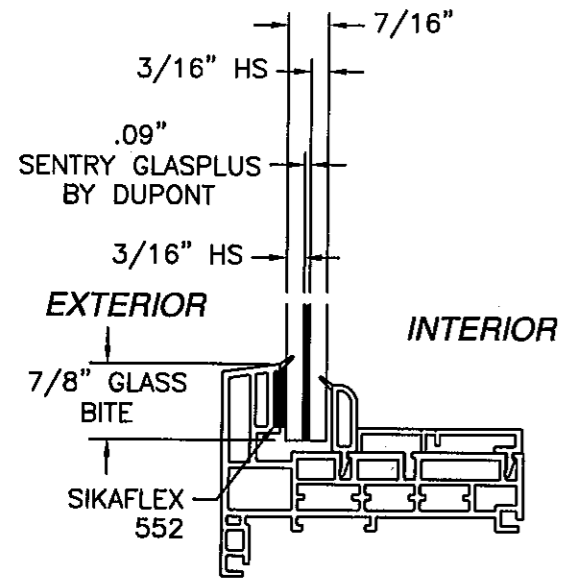

GLASS TYPE A

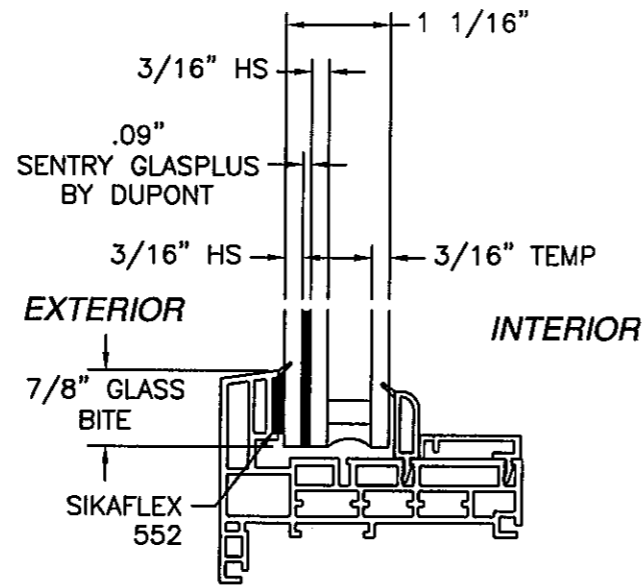

GLASS TYPE B

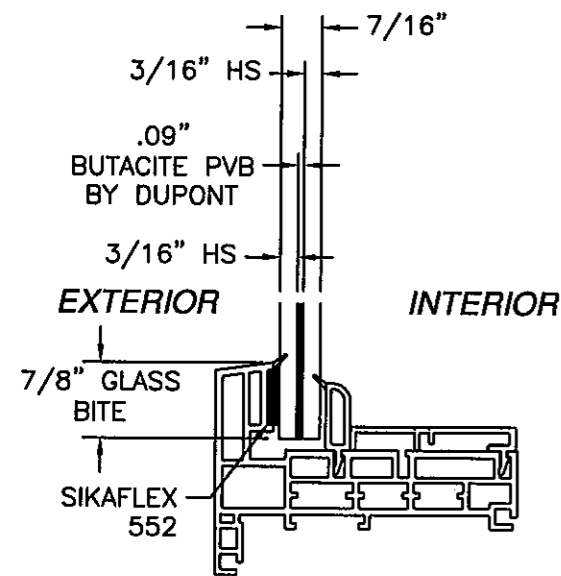

GLASS TYPE C

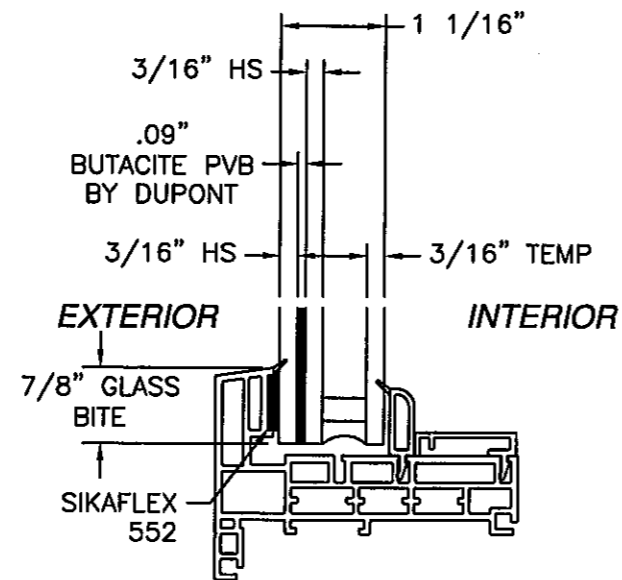

GLASS TYPE D

REVISIONS			
REV	DESCRIPTION	DATE	APPROVED
A	PER DADE LETTER DATED 2-4-10	03/25/10	R.L.
C	NO CHANGE THIS SHEET	10/27/11	J.J.

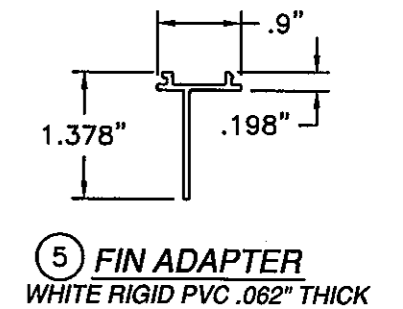
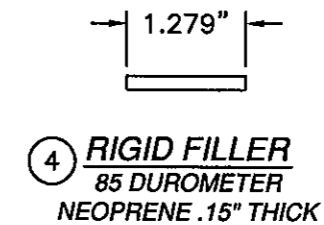
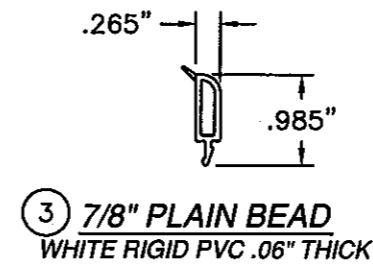
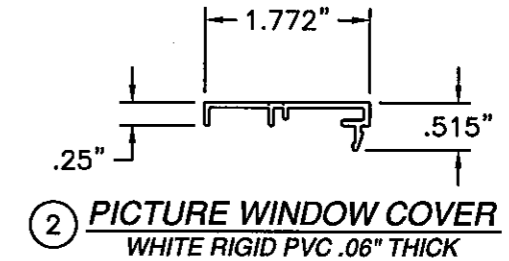
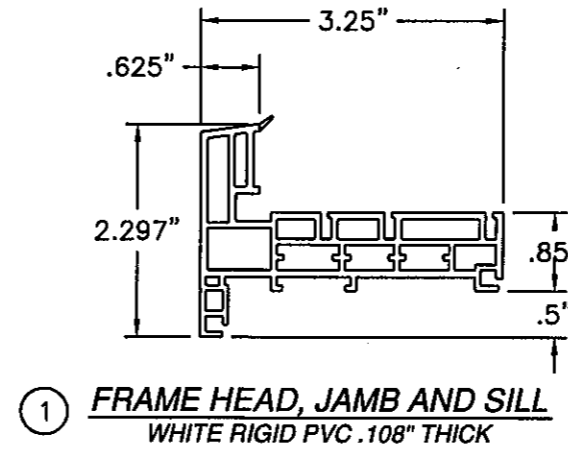

PRODUCT REVISED  
as complying with the Florida  
Building Code 11-1114.19  
Acceptance No. 08/11/2015  
Expiration/Date  
By *[Signature]*  
Miami Dade Product Control

PGT INDUSTRIES  
1070 TECHNOLOGY DRIVE  
NOKOMIS, FL 34275

PW2720 PVC FIXED WINDOW IMPACT  
PW2820 PVC FIXED WINDOW IMPACT  
GLAZING DETAILS AND COMPONENTS

DRAWN: TJH	DWG NO. 08-00885	REV C
SCALE NTS	DATE 10/21/09	SHEET 7 OF 7

