



BUILDING CODE COMPLIANCE OFFICE (BCCO)
 PRODUCT CONTROL DIVISION

MIAMI-DADE COUNTY, FLORIDA
 METRO-DADE FLAGLER BUILDING
 140 WEST FLAGLER STREET, SUITE 1603
 MIAMI, FLORIDA 33130-1563
 (305) 375-2901 FAX (305) 375-2908

NOTICE OF ACCEPTANCE (NOA)

PGT Industries
 P.O. Box 1529
 Nokomis, FL 34274

SCOPE:

This NOA is being issued under the applicable rules and regulations governing the use of construction materials. The documentation submitted has been reviewed by Miami-Dade County Product Control Division and accepted by the Board of Rules and Appeals (BORA) to be used in Miami Dade County and other areas where allowed by the Authority Having Jurisdiction (AHJ).

This NOA shall not be valid after the expiration date stated below. The Miami-Dade County Product Control Division (In Miami Dade County) and/or the AHJ (in areas other than Miami Dade County) reserve the right to have this product or material tested for quality assurance purposes. If this product or material fails to perform in the accepted manner, the manufacturer will incur the expense of such testing and the AHJ may immediately revoke, modify, or suspend the use of such product or material within their jurisdiction. BORA reserves the right to revoke this acceptance, if it is determined by Miami-Dade County Product Control Division that this product or material fails to meet the requirements of the applicable building code.

This product is approved as described herein, and has been designed to comply with the Florida Building Code, including the High Velocity Hurricane Zone.

DESCRIPTION: Series "SH-4000" Aluminum Single Hung Window

APPROVAL DOCUMENT: Drawing No. 2736, titled "Alum. Single Hung Window W/ STD. MTG. Rail", sheets 1 through 7 of 7, prepared, signed and sealed by Robert L. Clark, P.E., dated 12/15/04 with revision "F", on 09/20/06, bearing the Miami-Dade County Product Control Renewal Stamp with the Notice of Acceptance number and expiration date by the Miami-Dade County Product Control Division.

MISSILE IMPACT RATING: None

LABELING: Each unit shall bear a permanent label with the manufacturer's name or logo, city, state and following statement: "Miami-Dade County Product Control Approved", unless otherwise noted herein.

RENEWAL of this NOA shall be considered after a renewal application has been filed and there has been no change in the applicable building code negatively affecting the performance of this product.

TERMINATION of this NOA will occur after the expiration date or if there has been a revision or change in the materials, use, and/or manufacture of the product or process. Misuse of this NOA as an endorsement of any product, for sales, advertising or any other purposes shall automatically terminate this NOA. Failure to comply with any section of this NOA shall be cause for termination and removal of NOA.

ADVERTISEMENT: The NOA number preceded by the words Miami-Dade County, Florida, and followed by the expiration date may be displayed in advertising literature. If any portion of the NOA is displayed, then it shall be done in its entirety.

INSPECTION: A copy of this entire NOA shall be provided to the user by the manufacturer or its distributors and shall be available for inspection at the job site at the request of the Building Official.

This NOA revises NOA # 05-0104.05 and, consists of this page 1 and evidence page E-1 and E-2, as well as approval document mentioned above.

The submitted documentation was reviewed by **Jaime D. Gascon, P.E.**



J. Gascon
 10/20/06

NOA No 06-0706.04
 Expiration Date: September 30, 2011
 Approval Date: October 19, 2006

PGT Industries

NOTICE OF ACCEPTANCE: EVIDENCE SUBMITTED

A. DRAWINGS

1. Manufacturer's die drawings and sections.
2. Drawing No 2736, titled "Series "Alum. Single Hung Window W/STD. MTG. Rail" Sheets 1 through 9 of 9, prepared by the manufacture dated 12/15/04 with revision "D", on 12/15/04, signed and sealed by Robert L. Clark, P.E.

B. TESTS

1. Test reports on 1) Uniform Static Air Pressure Test, Loading per FBC, TAS 202-94 along with marked-up drawings and installation diagram of aluminum single hung window, prepared by Fenestration Testing Laboratory, Inc., Test Report No. **FTL-3654** signed and sealed by Joseph C. Chan, P.E.
"Submitted under NOA # 058-0104.05"
2. Test reports on 1) Air Infiltration Test, per FBC, TAS 202-94
2) Uniform Static Air Pressure Test, Loading per FBC, TAS 202-94
3) Water Resistance Test, per FBC, TAS 202-94
4) Forced Entry Test, per FBC 2411.3.2.1 (b) and TAS 202-94
along with marked-up drawings and installation diagram of aluminum single hung windows, prepared by Fenestration Testing Laboratory, Inc., Test Report No. **FTL-2959, 2960, 2961, 2962, 2963 and 2964** dated various, signed and sealed by Antonio Acevedo, P.E. **"Submitted under NOA # 058-0104.05"**
3. Test reports on 1) Air Infiltration Test, per FBC, TAS 202-94
2) Uniform Static Air Pressure Test, Loading per FBC, TAS 202-94
3) Water Resistance Test, per FBC, TAS 202-94
4) Forced Entry Test, per FBC 2411.3.2.1 (b) and TAS 202-94
along with marked-up drawings and installation diagram of aluminum single hung windows, prepared by Fenestration Testing Laboratory, Inc., Test Report No. **FTL-4179** dated April 07, 2004, signed and sealed by Edmundo J. Largaespada, P.E.
"Submitted under NOA # 058-0104.05"
4. Test reports on 1) Air Infiltration Test, per FBC, TAS 202-94
2) Uniform Static Air Pressure Test, Loading per FBC, TAS 202-94
3) Water Resistance Test, per FBC, TAS 202-94
4) Forced Entry Test, per FBC 2411.3.2.1 (b) and TAS 202-94
along with marked-up drawings and installation diagram of aluminum single hung windows, prepared by Fenestration Testing Laboratory, Inc., Test Report No. **FTL-4379** dated 11/04/04, signed and sealed by Edmundo J. Largaespada, P.E.

Jaime D. Gascon, P.E.

Chief, Product Control Division
NOA No 06-0706.04

Expiration Date: September 30, 2011

Approval Date: October 19, 2006

PGT Industries

NOTICE OF ACCEPTANCE: EVIDENCE SUBMITTED

C. CALCULATIONS

1. Revised Anchor Calculations, ASTM-E 1300-02, and structural analysis, prepared by PGT Industries, dated 09/20/06, signed and sealed by Robert L. Clark, P.E.

D. QUALITY ASSURANCE

1. Miami Dade Building Code Compliance Office (BCCO).

E. MATERIAL CERTIFICATIONS

1. None.

F. STATEMENTS

1. Statement letter of conformance and no financial, dated May 11, 2001, signed by Robert L. Clark, P.E.
"Submitted under NOA # 04-0714.06"
2. Laboratory compliance statement as part of test reports for Test Report no. **FTL-2959, 2960, 2961, 2962, 2963** and **2964**, issued by Fenestration Testing Laboratory, Inc., signed and sealed by signed and sealed by Antonio Acevedo, P.E.
"Submitted under NOA # 04-0714.06"

G. OTHER

1. Letter from the consultant stating that the product is in compliance with the Florida Building Code (FBC).
2. Notice of Acceptance No. 05-0104.05, issued to PGT Industries, Series SH-4000 Aluminum Single Hung Window, approved on 03/24/05, and expiring on 09/30/06.



Jaime D. Gascon, P.E.
Chief, Product Control Division
NOA No 06-0706.04

Expiration Date: September 30, 2011
Approval Date: October 19, 2006

GENERAL NOTES: NON-IMPACT WINDOW

1. GLAZING OPTIONS:
 - A. 7/8" ANNEALED GLASS
 - B. 1/8" TEMPERED GLASS
 - C. 3/16" ANNEALED GLASS
 - D. 1/4" ANNEALED GLASS
 - E. 3/16" TEMPERED GLASS
 - F. 1/4" TEMPERED GLASS
 - G. 1/2" LG. GLASS CONSISTING OF (2) LITES OF 1/8" ANNEALED GLASS WITH A 1/4" AIR SPACE BETWEEN.
 - H. 1/2" LG. GLASS CONSISTING OF (1) LITE OF 3/16" ANNEALED GLASS AND (1) LITE OF 1/8" ANNEALED GLASS WITH A 3/16" AIR SPACE BETWEEN.
 - I. 1/2" LG. GLASS CONSISTING OF (2) LITES OF 1/8" TEMPERED GLASS WITH A 1/4" AIR SPACE BETWEEN.
 - J. 1/2" LG. GLASS CONSISTING OF (1) LITE OF 3/16" TEMPERED GLASS AND (1) LITE OF 1/8" TEMPERED GLASS WITH A 3/16" AIR SPACE BETWEEN.
2. CONFIGURATION: 1H 0X
3. DESIGN PRESSURES: (SEE TABLE 1, SHEET 3)
 - A. NEGATIVE DESIGN LOADS BASED ON TESTED PRESSURE AND GLASS TABLES ASTM E 1300-02.
 - B. POSITIVE DESIGN LOADS BASED ON WATER TEST PRESSURE AND GLASS TABLES ASTM E 1300-02.
 - C. DESIGN PRESSURES LESS THAN 40 PSF ARE NOT APPLICABLE IN MIAMI-DADE COUNTY.
4. FOR ANCHORAGE REQUIREMENTS SEE SHEETS 6 AND 7. THE 33 LG STRESS INCREASE HAS NOT BEEN USED IN THE DESIGN OF THIS PRODUCT.
5. SHUTTERS ARE REQUIRED WHERE IMPACT RESISTANCE IS REQUIRED. SHUTTERS MUST BE MIAMI-DADE COUNTY APPROVED FOR INSTALLATION IN MIAMI-DADE COUNTY.
6. SEALANTS: FRAME CORNERS, FIXED MEETING RAIL SEAMS AND VENT CORNERS SEALED WITH CLEAR COLORED SEALANT.
7. REFERENCES: TEST REPORTS: FTL-2959, FTL-2960, FTL-2961, FTL-2963, FTL-3654, FTL-4179, AND FTL-4379.
ELCO TEXTRON NOA: 04-0721-01, 03-0225-05
ANSI/AF&PA NDS-2001 FOR WOOD CONSTRUCTION
ADM-2000 ALUMINUM DESIGN MANUAL
8. THIS PRODUCT HAS BEEN DESIGNED & TESTED TO COMPLY WITH THE REQUIREMENTS OF THE FLORIDA BUILDING CODE, 2004 EDITION FOR THE HIGH VELOCITY HURRICANE ZONE (HVH2).

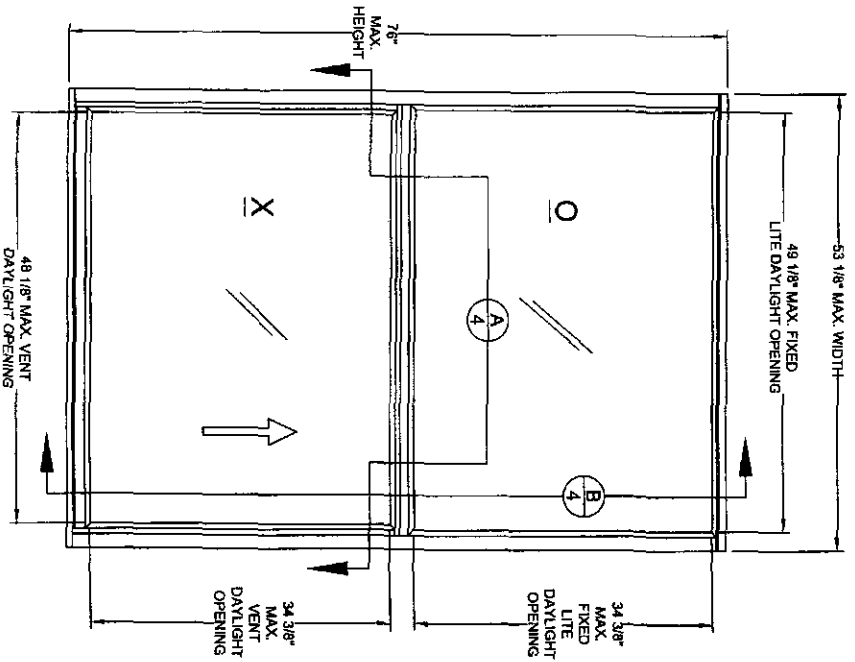

OUTSIDE ELEVATION

Revised By:	12/15/04	Change Note 3 to ASTM E1360-02 AND ADD AIR SPACE DIM. TO LG. GLASS RECIPIES
Drawn By:	12/15/04	ADD AIR SPACE DIM. TO LG. GLASS RECIPIES AND (7) TEMPERED TG (OPTIONS)
Checked By:	12/15/04	REDESIGN & ADDED ALT. EXTR. ADD'L GLASS TYPES & MAP.

1070 TECHNOLOGY DRIVE
NOKOMIS, FL 32755
P.O. BOX 1529
NOKOMIS, FL 32074



General Notes and Elevation
ALUM. SINGLE HUNG WINDOW, STD. MTG. RAIL
 SH4000
 NTS 1 of 7
 2736
 F

NOA DRAWING MAP

SHEET

GENERAL NOTES	1
ELEVATIONS	1
GLAZING DETAILS	2
DESIGN PRESSURES	3
VERT. SECTIONS	4
HORIZ. SECTIONS	4
PARTS LIST	5
EXTRUSIONS	5
ANCHORAGE	6-7

PRODUCT EXTENDED
 An energy rating was provided by the Florida Building Code Authority. The Energy Rating is: **04-0204-04**
 Approved by the Florida Building Code Authority on: **09/20/04**
 Approved by the Florida Building Code Authority on: **09/20/04**

[Signature]
 Robert L. Clark, P.E.
 PE #39712
 Structural

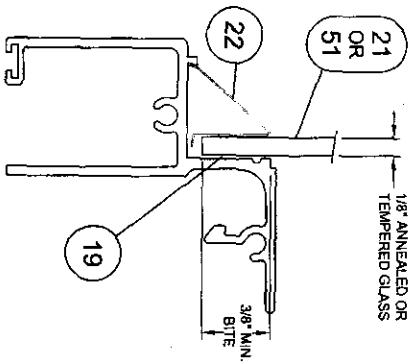

1/8" GLAZING DETAIL
(ORIGINAL DESIGN)

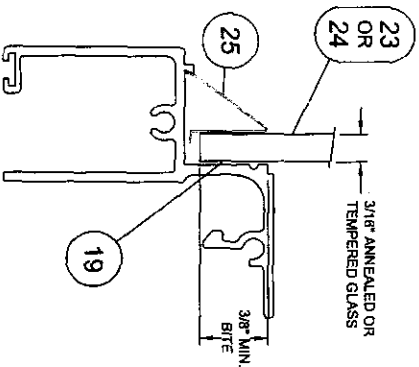

3/16" GLAZING DETAIL
(ORIGINAL DESIGN)

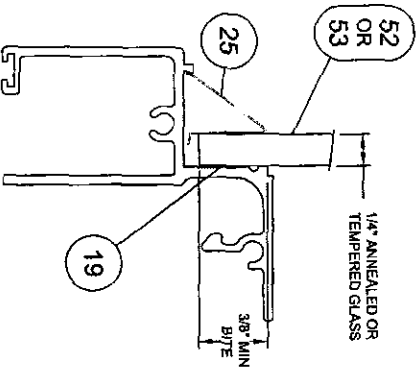

1/4" GLAZING DETAIL
(ORIGINAL DESIGN)

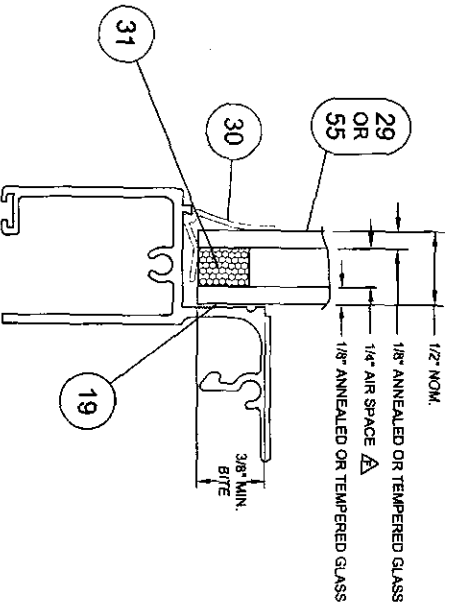

1/2" I.G. GLAZING DETAIL
(ORIGINAL DESIGN)

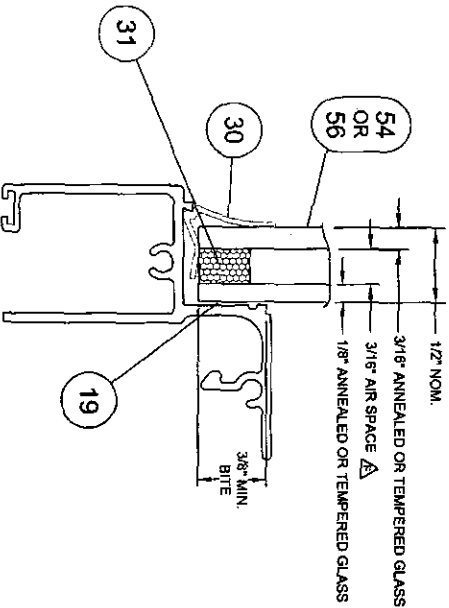

1/2" I.G. GLAZING DETAIL
(ORIGINAL DESIGN)

Drawn By: F.K.	Date: 12/15/04	Checked By: J.J.	Date: 5/26/05
Rev. No: 0000005	Rev. Date: 08/20/08	Rev. No: D	Rev. Date: 5/26/05
Project: ADD AIR SPACE DIM. TO I.G. GLASS DETAILS & ITEMS 55 & 56	Project: ADD AIR SPACE DIM. TO I.G. GLASS DETAILS & ITEMS 55 & 56	Project: ADD 1/8" AIR SPACE TO I.G. GLAZING DETAILS	Project: ADD 1/8" AIR SPACE TO I.G. GLAZING DETAILS
Rev. Description: ADD 1/8" AIR SPACE TO I.G. GLAZING DETAILS	Rev. Description: ADD 1/8" AIR SPACE TO I.G. GLAZING DETAILS	Rev. Description: REDRAWN ORIG. AND ADDED ALT. GLAZING DETAILS.	Rev. Description: REDRAWN ORIG. AND ADDED ALT. GLAZING DETAILS.

1070 TECHNICAL DRIVE
NOKOMIS, FL 32475
P.O. BOX 1528
NOKOMIS, FL 32474



Product Code: 594600	Scale: Full	Sheet: 2	Total Sheets: 7	Drawing No: 2736
ALUM. SINGLE HUNG WINDOW, STD. MTG. RAIL				
Vashy Butler				

[Signature]
Robert L. Clark, P.E.
PE #3912
Structural

PRODUCT REVIEWED
in compliance with the Florida
Building Code.
Approved by the **DEPT. OF**
Regulation, Design, & Safety
Division of Building Code
1070 Technical Drive
Nokomis, FL 32475

COMPARATIVE ANALYSIS:

TABLE 1.

WINDOW WIDTH	GLASS TYPE	WINDOW HEIGHT						
		26"	36 3/8"	50 5/8"	63"	76"		
19 1/8"	A	+56.7	+56.7	-90.0	+56.7	-71.0	+43.8	-43.8
	B,E,F	+56.7	+56.7	-90.0	+56.7	-90.0	+56.7	-73.0
	C,D,G,H,I,J	+56.7	+56.7	-90.0	+56.7	-90.0	+56.7	-66.4
24"	A	+56.7	+56.7	-90.0	+56.7	-90.0	+56.7	-38.2
	B,E,F	+56.7	+56.7	-90.0	+56.7	-90.0	+56.7	-63.6
	C,D,G,H,I,J	+56.7	+56.7	-90.0	+56.7	-90.0	+56.7	-38.2
26 1/2"	A	+56.7	+56.7	-90.0	+56.7	-90.0	+56.7	-57.9
	B,E,F	+56.7	+56.7	-90.0	+56.7	-90.0	+56.7	-81.1
	C,D,G,H,I,J	+56.7	+56.7	-90.0	+56.7	-90.0	+56.7	-36.3
32"	A	+56.7	+56.7	-90.0	+56.7	-90.0	+56.7	-55.0
	B,E,F	+56.7	+56.7	-90.0	+56.7	-90.0	+56.7	-74.6
	C,D,G,H,I,J	+56.7	+56.7	-90.0	+56.7	-90.0	+56.7	-33.8
37"	A	+56.7	+56.7	-90.0	+56.7	-90.0	+56.7	-51.3
	B,E,F	+56.7	+56.7	-90.0	+56.7	-90.0	+56.7	-80.0
	C,D,G,H,I,J	+56.7	+56.7	-90.0	+56.7	-90.0	+56.7	-33.0
40"	A	+56.7	+56.7	-90.0	+56.7	-90.0	+56.7	-50.0
	B,E,F	+56.7	+56.7	-90.0	+56.7	-90.0	+56.7	-72.8
	C,D,G,H,I,J	+56.7	+56.7	-90.0	+56.7	-90.0	+56.7	-33.0
44"	A	+56.7	+56.7	-90.0	+56.7	-90.0	+56.7	-33.0
	B,E,F	+56.7	+56.7	-90.0	+56.7	-90.0	+56.7	-48.0
	C,D,G,H,I,J	+56.7	+56.7	-90.0	+56.7	-90.0	+56.7	-55.0
48"	A	+56.7	+56.7	-90.0	+56.7	-90.0	+56.7	-50.0
	B,E,F	+56.7	+56.7	-90.0	+56.7	-90.0	+56.7	-72.8
	C,D,G,H,I,J	+56.7	+56.7	-90.0	+56.7	-90.0	+56.7	-33.0
53 1/8"	A	+56.7	+56.7	-90.0	+56.7	-90.0	+56.7	-33.0
	B,E,F	+56.7	+56.7	-90.0	+56.7	-90.0	+56.7	-42.1
	C,D,G,H,I,J	+56.7	+56.7	-90.0	+56.7	-90.0	+56.7	-55.0

GLASS TYPES:

A. 1/8" ANNEALED	FTL-2961, 2963
* B. 1/8" TEMPERED	FTL-2961, 2963
C. 3/16" ANNEALED	FTL-2960
* D. 1/4" ANNEALED	FTL-2960
E. 3/16" TEMPERED	FTL-2959, 4179, 4379
* F. 1/4" TEMPERED	FTL-2959, 4179, 4379
G. 1/2" I.G. (1/18" A, 1/4" AIR SPACE, 1/8" A)	FTL-3654
* H. 1/2" I.G. (3/16" A, 3/16" AIR SPACE, 1/8" A)	FTL-3654
* I. 1/2" I.G. (1/8" T, 1/4" AIR SPACE, 1/8" T)	FTL-3654
* J. 1/2" I.G. (3/16" T, 3/16" AIR SPACE, 1/8" T)	FTL-3654

* UPGRADE FROM GLASS TYPE TESTED

PRODUCT CERTIFIED
 The Glass was tested in accordance with the Florida Building Code, Chapter 6, Part 9, Section 903.6.4, and the Florida Building Code, Chapter 6, Part 9, Section 903.6.4, and the Florida Building Code, Chapter 6, Part 9, Section 903.6.4.

100 AIR SPACE, 100 I.G. GLASS REQUIREMENTS
 UPGRADE TABLE DESIGN PRESSURES PER ASTM E 1300-02.
 ADD CLASS TYPE A & L (TEMPERED OR ANNEALED) TO REDUCE MAX. NEGATIVE DP FROM -110 TO -90 PSF.
 REPAIRMAN AND COMBINED DP TABLES. ADD CLASS TYPES B, D, E & H (TEMPERED).
 DATED 05/26/06

100 TECHNOLOGY DRIVE
 NOKOMIS, FL 34475
 P.O. BOX 1539
 NOKOMIS, FL 34474



DESIGN PRESSURES
 ALLUM. SINGLE HUNG WINDOW, STD. MTG. RAIL
 SH4000
 Size: NTS
 Spacing: 3
 Depth: 7
 Type: F

Robert L. Clark, P.E.
 Robert L. Clark, P.E.
 PE #39172
 Structural

Formed By	DATE	Revision
F.K.	08/28/08	F
Revised By	DATE	Revision
J.J.	08/05/08	E
Formed By	DATE	Revision
F.K.	12/15/04	D
Formed By	DATE	Revision
F.K.	12/15/04	J.J.

ADD ITEMS 55 AND 56 TO NOTE 2.
 REMOVE AND REMOVE ALTERNATE EXTRUSIONS:
 REMOVE AND REMOVE ALTERNATE EXTRUSIONS

1070 TECHNOLOGY DRIVE
 NOKOMIS, FL 32755
 P.O. BOX 1328
 NOKOMIS, FL 32754

PGT
 Vastly Better

SECTIONS
 ALUM. SINGLE HUNG WINDOW, STD. MTG. RAIL

Standard	Size	Style	Standard
5H4000	1/2	4 or 7	2736

PRODUCT REVIEWED
 as complying with the Florida
 Building Code
 Approved by
 Robert Clark, P.E.
 PE #39712
 Stuchlik

SECTION B-B

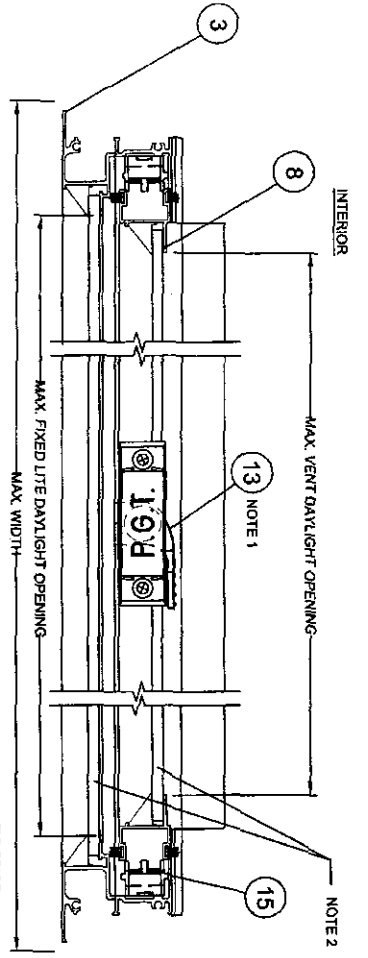
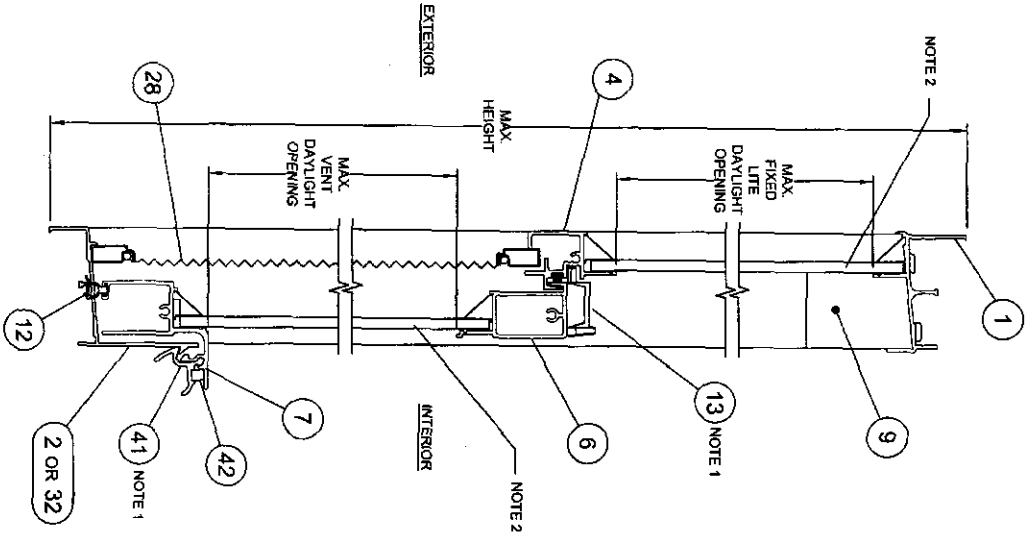

NOTES:

1. WINDOWS ARE EQUIPPED WITH ITEM 13, SWEEP LATCH LOCATED ON THE VENT TOP RAIL OR ITEM 41, BOTTOM LOCK LOCATED ON THE VENT BOTTOM RAIL.
2. WINDOWS ARE GLAZED WITH ONE OF THE FOLLOWING GLASS ITEMS 21, 23, 24, 29, 51, 52, 53, 54, 55, OR 56. ▽

SECTION A-A

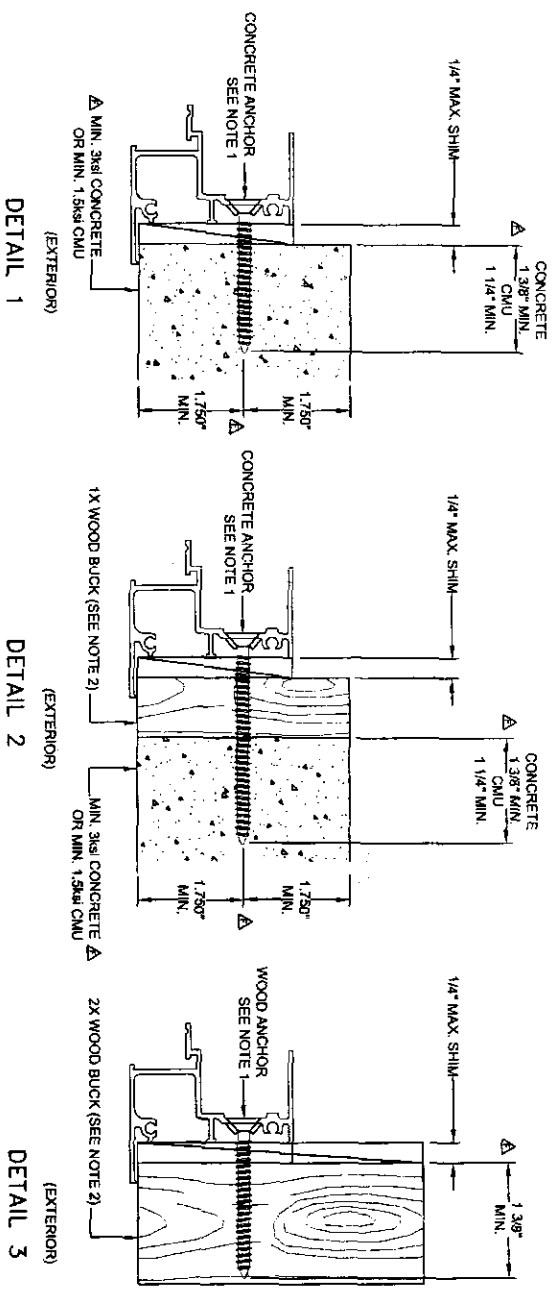

TYPICAL JAMB ANCHORAGE

- NOTES:
1. MIAMI-DADE COUNTY APPROVED ANCHOR TYPES: 1. ELOCO 1/4" TAPCON 2. ELOCO 1/4" S54 CRETE-FLEX MASONRY SCREWS 3. #12 SCREW
 2. FOR CONCRETE APPLICATIONS IN MIAMI-DADE COUNTY, USE ONLY ABOVE APPROVED 1/4" TAPCONS OR S54 CRETE-FLEX. MINIMUM DISTANCE FROM ANCHOR TO CONCRETE EDGE IS 1.750". FOR WOOD APPLICATIONS USE #12 STEEL, G8 SCREWS OR 1/4" ELOCO S54 CRETE-FLEX ANCHORS.
 3. WOOD BUCKS DEPICTED IN THE SECTIONS ON THIS PAGE AS 1X ARE BUCKS WHOSE TOTAL THICKNESS IS LESS THAN 1 1/2". WOOD BUCKS DEPICTED AS 2X ARE 1 1/2" THICK OR GREATER. INSTALLATION TO THE SUBSTRATE OF WOOD BUCKS TO BE ENGINEERED BY OTHERS OR AS APPROVED BY AUTHORITY HAVING JURISDICTION.
 4. WOOD BUCKS LESS THAN 1 1/2" THICK ARE OPTIONAL (PRODUCT MAY BE INSTALLED DIRECTLY TO CONCRETE).
 5. FOR ATTACHMENT TO ALUMINUM: THE MATERIAL SHALL BE A MINIMUM STRENGTH OF 6062-T5 AND A MINIMUM OF 1/16" THICK. THE ALUMINUM STRUCTURAL MEMBER SHALL BE OF A SIZE TO PROVIDE FULL SUPPORT TO THE WINDOW JAMB SIMILAR TO THAT SHOWN IN DETAIL 3 ABOVE FOR 2X WOOD BUCKS. THE ANCHOR SHALL BE A #12 SHEET METAL SCREW WITH FULL ENGAGEMENT INTO THE ALUMINUM. IF THESE CRITERIA ARE MET THE PRESSURES AND ANCHOR QUANTITIES SHOWN IN TABLE 2, SHEET 7 FOR ANCHOR TYPES 1 AND 2 IN CONCRETE MAY BE USED.
 6. ANCHORS ARE NOT REQUIRED IN THE HEAD OR SILL (REF. TEST REPORTS, FTL-4283 AND FTL-4378).
 7. 53 1/8" WIDE x 7/8" HIGH UNITS TESTED TO FULL DESIGN PRESSURE AT THE FOLLOWING SPACING:
 - A. JAMBS: 9" MAX. FROM CORNERS & 1/2" BELOW MEETING RAIL AND 1" ABOVE THE LOWER MEETING RAIL ANCHOR 3" MIN. ANCHOR SPACING.
 8. EQUALY SPACED ABOVE AND BELOW THE MEETING RAIL BETWEEN THE CORNER AND MEETING RAIL ANCHORS.
 9. MATERIALS, INCLUDING BUT NOT LIMITED TO STEEL SCREWS, THAT COME INTO CONTACT WITH OTHER DISSIMILAR MATERIALS SHALL MEET THE REQUIREMENTS OF FBC 2004, SECTION 2003.8.4 (SUPPLEMENT 2008).

Revised By:	Date:	Revisions:	1. REMOVE NOTES 1, 2 & 3. REMOVE NOTE 4. RE-OUTSIDE JAMB CASE SPECIFY CONCRETE. CALL EDGE DISTANCE & CHECK EMBED. IN DETAILS
F.K.	08/22/06	F	
J.J.	08/05/05	E	REVERSE ANCHOR SHITS & REVERSE ANCHORAGE NOTES
F.K.	12/15/04	D	REPAIR VAN, UPDATED NOTES & REMOVED HEAD & SILL SECTIONS
F.K.	12/15/04	COR. J.L.	08/26/05

1070 TECHNOLOGY DRIVE
NOKOMIS, FL 32475
NOKOMIS, FL 32474

P&T
P&T Builders

ANCHORAGE DETAILS
ALUM. SINGLE HUNG WINDOW, STD. MTG. RAIL

Scale: NTS
Sheet: 6 of 7
Drawing No: 2736

Product reviewed in compliance with the Florida Building Code, Chapter 6, Part 905.05, Florida Building Code, Chapter 6, Part 905.05, Florida Building Code, Chapter 6, Part 905.05, Florida Building Code, Chapter 6, Part 905.05.

Robert Clark, P.E.
PE #39712
Structural

ITEM	DESCRIPTION	PCT #	VENDOR/MAT'L	DWG.#
1	FLANGED FRAME HEAD	62703	6063-16	2703
2	FLANGED FRAME SILL	62704	6063-16	2704
3	FLANGED FRAME JAMB	62705	6063-16	2705
4	FIXED MEETING RAIL	6534627	6063-18	2706
5	#8 X 1.000 QUAD PAN HEAD SMS	78190	SPENCER OR =	
6	VENT TOP RAIL	6334622	6063-16	2707
7	VENT BOTTOM RAIL	6334623	6063-16	2708
8	VENT SIDE RAIL	6334624	6063-16	2709
9	VENT STOP	6063-16	6063-16	2710
10	VENT CAM INSERT (L.H. & R.H.)	42900	NYLON 6/8	2711
11	#8 X .750 QUAD PAN HEAD SMS	7834624	SPENCER OR =	
12	WEATHERSTRIP VINYL BULB W/LEAF	617249	TEAM PLASTICS OR =	
13	SWEEP LATCH	71966	NATIONWIDE OR =	
14	#8 X .625 PHILLIPS FLAT HEAD SMS	7858	SPENCER OR =	
15	BALANCE		CALDWELL OR =	
16	WEATHERSTRIP .187 X 270 FIN	61062	TEAM PLASTICS OR =	
17	WEATHERSTRIP .187 X 200 FIN	67918	SCHIEL OR =	
18	BALANCE TAKE-OUT CLIP	71210M	CULWELL OR =	
19	SILICON GLAZING SEALANT	62899	DOM. GE OR =	
21	D53 1/8 ANNEALED GLASS		FLORIDA SCREEN OR =	
22	1/2 ANNEALED GLASS		FLORIDA SCREEN OR =	
23	3/16 ANNEALED GLASS		FLORIDA SCREEN OR =	
24	3/16 TEMPERED GLASS		FLORIDA SCREEN OR =	
25	3/16 1/4 GLAZING BEAD	65196	FLORIDA SCREEN OR =	
26	#8 X 1.000 QUAD PAN HEAD SMS	78190	SPENCER OR =	
27	1/4 X 1/2 OPEN CELL FOAM PAD			
28	SCREEN ASSEMBLY			
29	1/2 I.G. GLASS (1/8" A, 1/4" AIR SPACE, 1/8" A)			
30	1/2 I.G. GLAZING BEAD	1253	TEAM PLASTICS OR =	
31	SWINGE			
32	FLANGED FRAME SILL	62751	6063-16	2751
41	VENT BOTTOM RAIL LOCK	62740	6063-18	2740
42	VENT BOTTOM RAIL LOCK SPRING			
43	1 X 2 X 1/16 FOAM GLASSSET			
44	1/8 TEMPERED GLASS			
51	1/4 ANNEALED GLASS			
52	1/4 ANNEALED GLASS			
54	1/2 I.G. GLASS (3/16 A, 3/16 AIR SPACE, 1/8 A)			
55	1/2 I.G. GLASS (1/8 T, 1/4 AIR SPACE, 1/8 T)			
56	1/2 I.G. GLASS (1/8 T, 3/16 AIR SPACE, 1/8 T)			

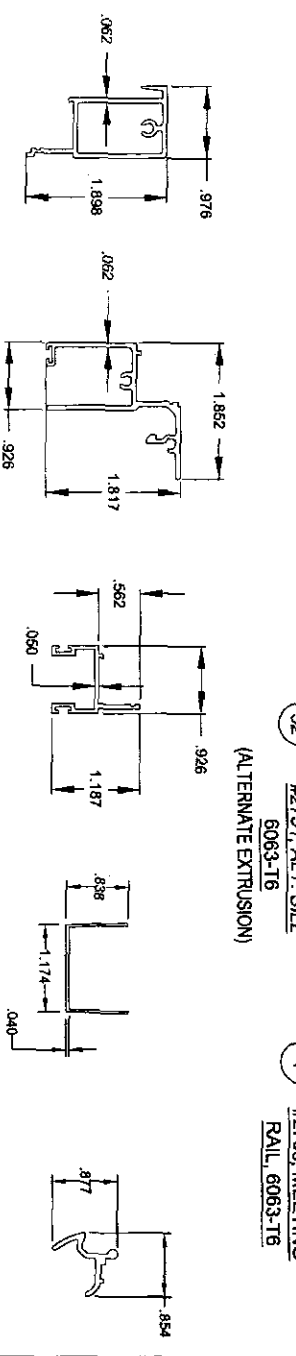
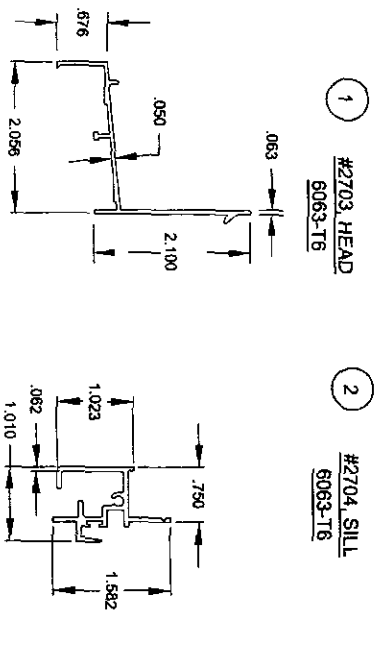
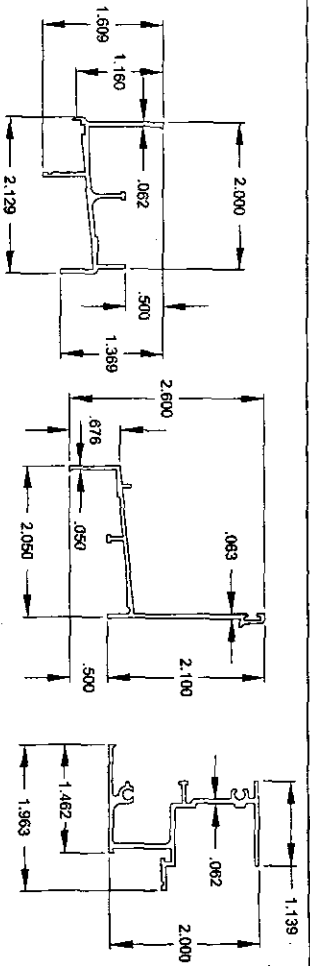

Trans By	Date	Revisions
F.K.	09/20/06	ADD AIR SPACE DIM. TO I.G. GLASS REQUIRES ITEMS 29, 54, 55 & 56.
J.J.	08/29/05	PARIS LIST AND EXTRUSIONS CONSOLIDATION.
F.K.	12/15/04	ADD ITEMS 53 & 54 (TEMPERED I.G. GLASS OPTIONS).
F.K.	12/15/04	DEFINITE SSR ADDED ITEM 9 DWG NOS. & ALLOY.
F.K.	12/15/04	UPDATED PARTS LIST W/ DWG NOS. & VENDORS.
Checked By	J.J.	226/06
Drawn By	J.J.	226/06

1170 TECHNOLOGY DRIVE
 MONROE, LA 70475
 NICKONS, P.L. 34274

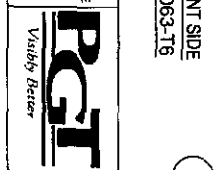

Part Number: **PARIS LIST AND EXTRUSIONS**
 THE ALUM. SINGLE HUNG WINDOW, STD. MTG. RAIL
 SH-4000 Size: Half 5 7 Drawing No: 2796

PRODUCT REVISED
 as described with the Parallel Building Code.
 Approved by the **06-09-06** of Extrusion Dept. **2718/11**
 By **[Signature]**
 Robert L. Clark, P.E.
 PE #39712
 Structural

9/25/06

QUANTITY OF ANCHORS REQUIRED EACH JAMB

TABLE 2.

ANCHORS/SUBSTRATE	GLASS TYPE	WINDOW HEIGHT																	
		25"				38 3/8"				50 5/8"				63"				76"	
WINDOW WIDTH		3W	2W	1,2/C	3W	2W	1,2/C	3W	2W	1,2/C	3W	2W	1,2/C	3W	2W	1,2/C	3W	2W	1,2/C
19 1/8"	A	4	4	4	4	4	4	4	4	4	4	4	4	4	4	4	4	4	4
	B,E,F	4	4	4	4	4	4	4	4	4	4	4	4	4	4	4	4	4	4
24"	A	4	4	4	4	4	4	4	4	4	4	4	4	4	4	4	4	4	4
	B,E,F	4	4	4	4	4	4	4	4	4	4	4	4	4	4	4	4	4	4
26 1/2"	A	4	4	4	4	4	4	4	4	4	4	4	4	4	4	4	4	4	4
	B,E,F	4	4	4	4	4	4	4	4	4	4	4	4	4	4	4	4	4	4
32"	A	4	4	4	4	4	4	4	4	4	4	4	4	4	4	4	4	4	4
	B,E,F	4	4	4	4	4	4	4	4	4	4	4	4	4	4	4	4	4	4
37"	A	4	4	4	4	4	4	4	4	4	4	4	4	4	4	4	4	4	4
	B,E,F	4	4	4	4	4	4	4	4	4	4	4	4	4	4	4	4	4	4
40"	A	4	4	4	4	4	4	4	4	4	4	4	4	4	4	4	4	4	4
	B,E,F	4	4	4	4	4	4	4	4	4	4	4	4	4	4	4	4	4	4
44"	A	4	4	4	4	4	4	4	4	4	4	4	4	4	4	4	4	4	4
	B,E,F	4	4	4	4	4	4	4	4	4	4	4	4	4	4	4	4	4	4
48"	A	4	4	4	4	4	4	4	4	4	4	4	4	4	4	4	4	4	4
	B,E,F	4	4	4	4	4	4	4	4	4	4	4	4	4	4	4	4	4	4
53 1/8"	A	4	4	4	4	4	4	4	4	4	4	4	4	4	4	4	4	4	4
	B,E,F	4	4	4	4	4	4	4	4	4	4	4	4	4	4	4	4	4	4

ANCHOR TYPE/SUBSTRATE KEY

- 3W = #1/2 SCREW IN WOOD
 - 2W = #1/4" SS4 CRETE-FLEX IN WOOD
 - 1,2/C = 1/4" TABCON OR 1/4" SS4 CRETE-FLEX IN CONCRETE
 - (SEE APPLICATION NOTES AND DETAILS ON SHEET 6)
 - NOTE: ANCHORS NOT REQUIRED IN HEAD OR SILL
- GLASS TYPE KEY
- A. 1/8" ANNEALED
 - B. 1/8" TEMPERED
 - C. 3/16" ANNEALED
 - D. 1/4" ANNEALED
 - E. 3/16" TEMPERED
 - F. 1/4" TEMPERED
 - G. 1/2" I.G. (1/8" A, 1/4" AIR SPACE, 1/8" A)
 - H. 1/2" I.G. (3/16" A, 3/16" AIR SPACE, 1/8" A)
 - I. 1/2" I.G. (1/8" T, 1/4" AIR SPACE, 1/8" T)
 - J. 1/2" I.G. (3/16" T, 3/16" AIR SPACE, 1/8" T)

Revised By: 08/23/06
 F.K. 08/23/06
 F.K. 08/23/06
 F.K. 12/15/04
 F.K. 12/15/04

Revision: F
 Description: ADD AIR SPACE DIM. TO I.G. GLASS REQ'P.
 Revision: D
 Description: REVISE TABLE ANCHOR QUANTITIES PER NEW ANCHOR CALC.
 Revision: J
 Description: NEW SHEET FOR ANCHOR SPACING

Checked By: J.J.
 Date: 5/28/06

1070 TECHNOLOGY DRIVE
 P.O. BOX 159
 NOKROSS, FL 34275
 NOKROSS, FL 34274



ANCHORAGE SPACING, 1/1 WINDOWS
 ALUM. SINGLE HUNG WINDOW, STD. MTG. RAIL
 SH-4000
 Scale: NTS
 Date: 7 of 7
 Drawing No.: 2736
 Rev: F

PRODUCT REVIEWED
 in compliance with the Florida
 Building Code
 Approved by the Florida Dept.
 of Building
 Inspection
 PE #39712
 Structural

Edward L. Clark, P.E.
 PE #39712
 Structural